

Halls office
**Fisher
Body**



**1971 FOLDING TOP
SERVICE MANUAL
"B & E" BODIES**

FOLDING TOP
"B" AND "E" STYLES

1971 FISHER BODY SERVICE MANUAL FOLDING TOP SUPPLEMENT

"B" AND "E" CONVERTIBLE STYLES

This publication contains the essential removal, installation, adjustment and maintenance procedures for servicing Folding Tops on all U.S. and Canadian built 1971 "B" and "E" Convertible Fisher Body Styles. All information, illustrations, and specifications contained in this publication are based on the latest product information available at the time of publication approval. The right is reserved to make changes at any time without notice.

FISHER BODY DIVISION
PART NO. 8704198-A

© 1970 GENERAL MOTORS CORPORATION
LITHO IN U.S.A.
DECEMBER 1970

FOLDING TOP

"B" AND "E" STYLES

INDEX

SUBJECT	PAGE	SUBJECT	PAGE
Introduction	1	Removal and Installation	22
Description	1	Folding Top Actuator Drive Cable-Right and/or	
Folding Top Trim		Left	23
Folding Top Cover and Back Curtain Assembly	3	Removal and Installation	23
Removal	3	Back Window Guide Control Link and Spring	24
Installation	10	Removal and Installation	24
Folding Top Cover (Less Back Curtain)	12	Folding Top Actuator Assembly	25
Removal	12	Removal	25
Installation	13	Installation	25
Back Curtain Assembly	15	Procedure for Synchronizing Folding Top	
Removal	15	Actuators	26
Installation	16	Folding Top Adjustments	26
Folding Top Silencer Assembly	17	Description	26
Removal	18	Checking Tension on Stacked Folding Top	26
Installation	19	Folding Top Stacked Position Tension Adjustment	27
Folding Top Side Quarter Pad Assembly	19	Locating Pin and Side Roof Rail Height	
Removal	19	Adjustment	28
Installation	20	Description	28
Folding Top Gutter	20	Procedure	30
Removal and Installation	20	Checking Tension of (Up Position) Side Roof	
Folding Top Hardware Components	22	Rails	30
Front Roof Rail Lock	22	Description	30
Removal and Installation	22	Procedure	30
Front Roof Rail Locating Pin	22	Side Roof Rail Tension Adjustment	32
Removal and Installation	22	Front Roof Rail Lock Hook Adjustment	33
Folding Top Electric Motor and/or Relay	22	Folding Top Main Hinge "Inward" Adjustment	35

INTRODUCTION

DESCRIPTION

1971 "B and E" convertible styles feature an "inward" folding top. Service replacement of folding top trim components is somewhat different from past models. Hardware construction and trim material attachment feature revised design concepts (Figs. 2 and 5). The convertible top involves a precise adjustment procedure which must be performed as outlined in this manual.

Side roof rails are hinged at the front, center and rear. The hinging design enables the side roof rails to fold "inwardly" when the top is lowered (Fig. 2). The roof cross bows, and trimstick stack to the rear of the side rails. The back window stacks under the roof rails and bows.

The inward folding top stacks to a flush position in the folding top compartment. The folding top well is shorter in length and provides full-width rear seat back comfort and leg room comparable to closed body styles.

Operation of the top is controlled by an electric switch. The top is powered by a reversible electric motor and two gear reduction units. One gear reduction unit, at the motor, operates the drive cables. Other gear reduction units are integral with the top actuator assemblies at each main hinge. Drive cables supply power to the actuators which, in turn, multiply the power to operate the top. During top operation, the solid-tempered glass back window is controlled by a guide control link and spring at each lower corner. The inward folding top gutter of convertible top trim

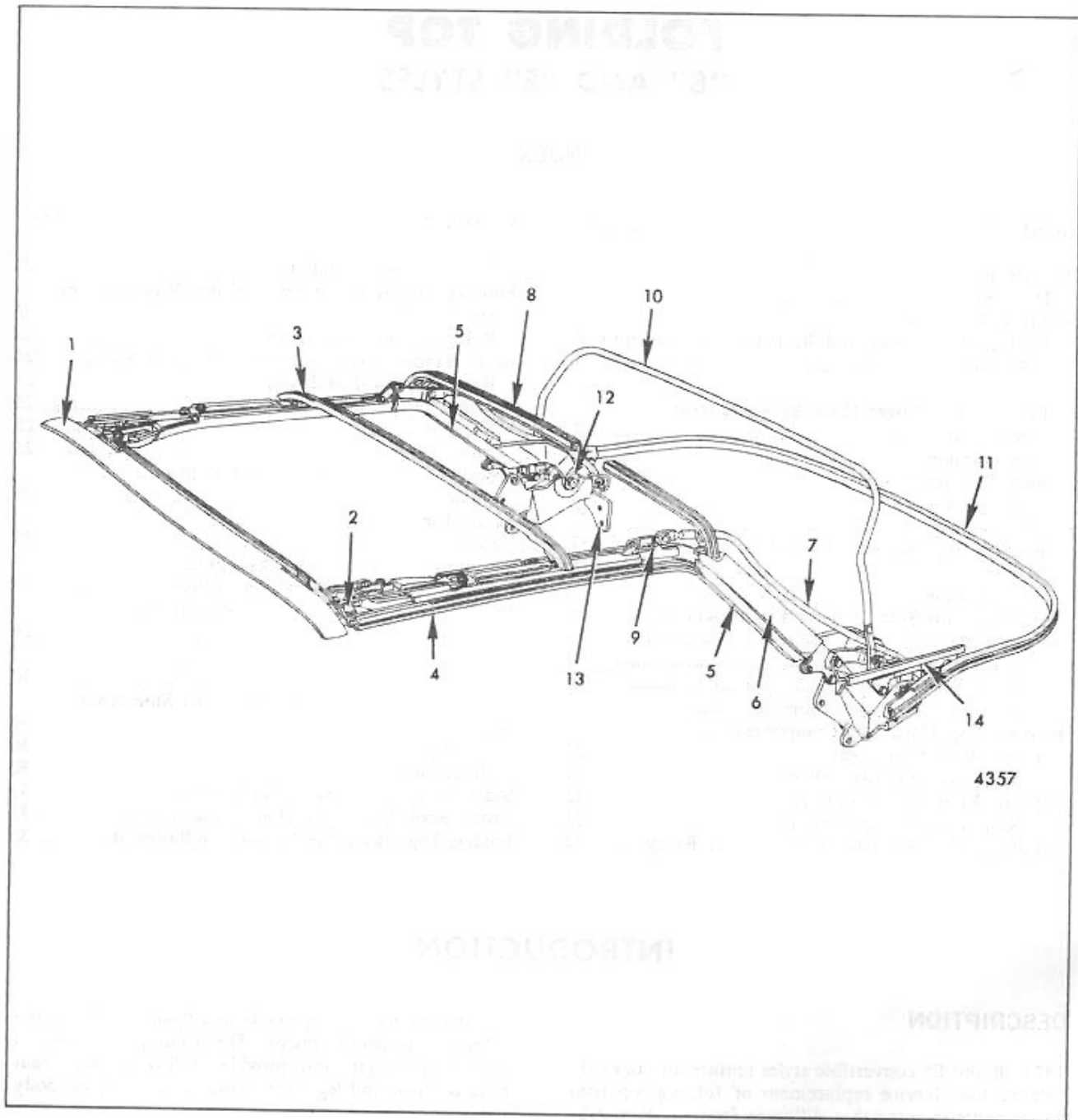

Fig. 1-Inward Folding Top Hardware Components

- | | | |
|---|---|--|
| 1. Front Roof Rail
(Also Fig. 3) | 6. Side Roof Outer Rear
Rail | 11. Rear Belt Rail
Trimstick |
| 2. Front Roof Rail Lock
(Also Fig. 15) | 7. Side Roof Rear
Control Link (Also
Fig. 21) | 12. Folding Top Actuator
Assembly (Also Fig.
20) |
| 3. Front Roof Bow and
Link Assembly | 8. Center Bow Assembly | 13. Main Hinge (Also
Fig. 30) |
| 4. Side Roof Front Rail | 9. Side Roof Rail Set
Screw (Also Fig. 24) | 14. Folding Top Cover
Pressure Bar |
| 5. Side Roof Inner Rear
Rail | 10. Rear Roof Bow and
Link Assembly | |

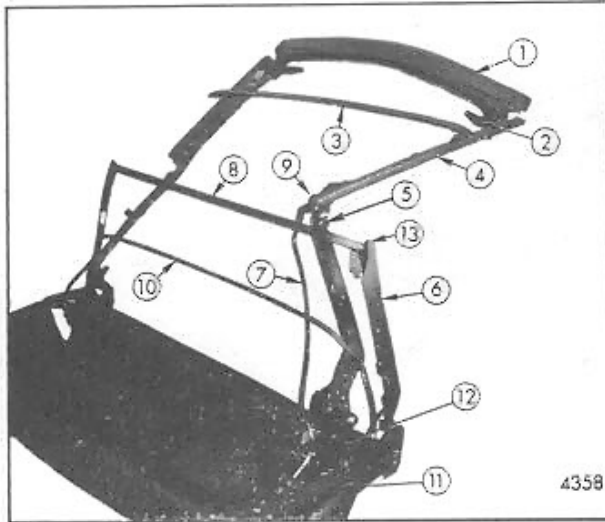

Fig. 2-Inward Folding Top Mechanism (Less Trim) Partially Lowered

- | | |
|---|--|
| 1. Front Roof Rail
(Also Fig. 3) | 8. Center Bow Assembly |
| 2. Front Roof Rail Lock
(Also Fig. 15) | 9. Side Roof Rail Set
Screw (Also Fig. 24) |
| 3. Front Roof Bow and
Link Assembly | 10. Rear Roof Bow and
Link Assembly |
| 4. Side Roof Front Rail | 11. Rear Belt Rail
Trimstick |
| 5. Side Roof Inner Rear
Rail | 12. Folding Top Actuator
Assembly (Also Fig.
20) |
| 6. Side Roof Outer Rear
Rail | 13. Side Roof Rail Rear
Inner to Outer Stop |
| 7. Side Roof Rear
Control Link (Also
Fig. 21) | |

FOLDING TOP TRIM

FOLDING TOP COVER AND BACK CURTAIN ASSEMBLY

Removal

IMPORTANT: Before removal operations are started, check and specifically note alignment condition of back curtain and top cover. Conditions, such as: wrinkles, draws, excess material, etc., can be corrected by adjusting trim material during assembly operations.

1. Apply protective covers to car as follows:
 - A. On rear deck section of car, particularly area adjacent to quarter belt finishing moldings, apply heavy padded cover to protect moldings and paint finish. Mask securely in place (Fig. 8).
 - B. On interior trim, floor and hood, use conventional covers.
2. With top lowered, detach top cover at front roof rail as follows (Fig. 3):
 - A. Remove front roof rail front weatherstrip.
 - B. Detach front roof rail rear weatherstrip at outer ends.
 - C. Detach top cover from front roof rail. Use care to avoid disturbing silencer attachment at front roof rail (Fig. 13).
 - D. With top a short distance above windshield header, remove attaching screws, loosen metal tabs and detach hold-down cables at front (Fig. 4).
3. With top raised, detach guide control links from lower corners of back window, slip compartment bag over links and lay links on floor.

construction controls drainage of water at the rear belt rail.

The left side rail folds before the right rail upon stacking. The side rail folding sequence causes the front roof rail to be non-parallel to the ground during a portion of top operation. This is a normal condition.

IMPORTANT: Before lowering the top, check the folding top compartment inside the car and in the rear compartment. Remove all luggage and parcels from the folding top compartment inside the car. Also, if necessary, clear away any luggage or miscellaneous parcels in the rear compartment which may have slid forward into the folding top compartment storage area. Failure to do so could result in breakage of the back window glass or damage to the folding top mechanism during operation of the top.

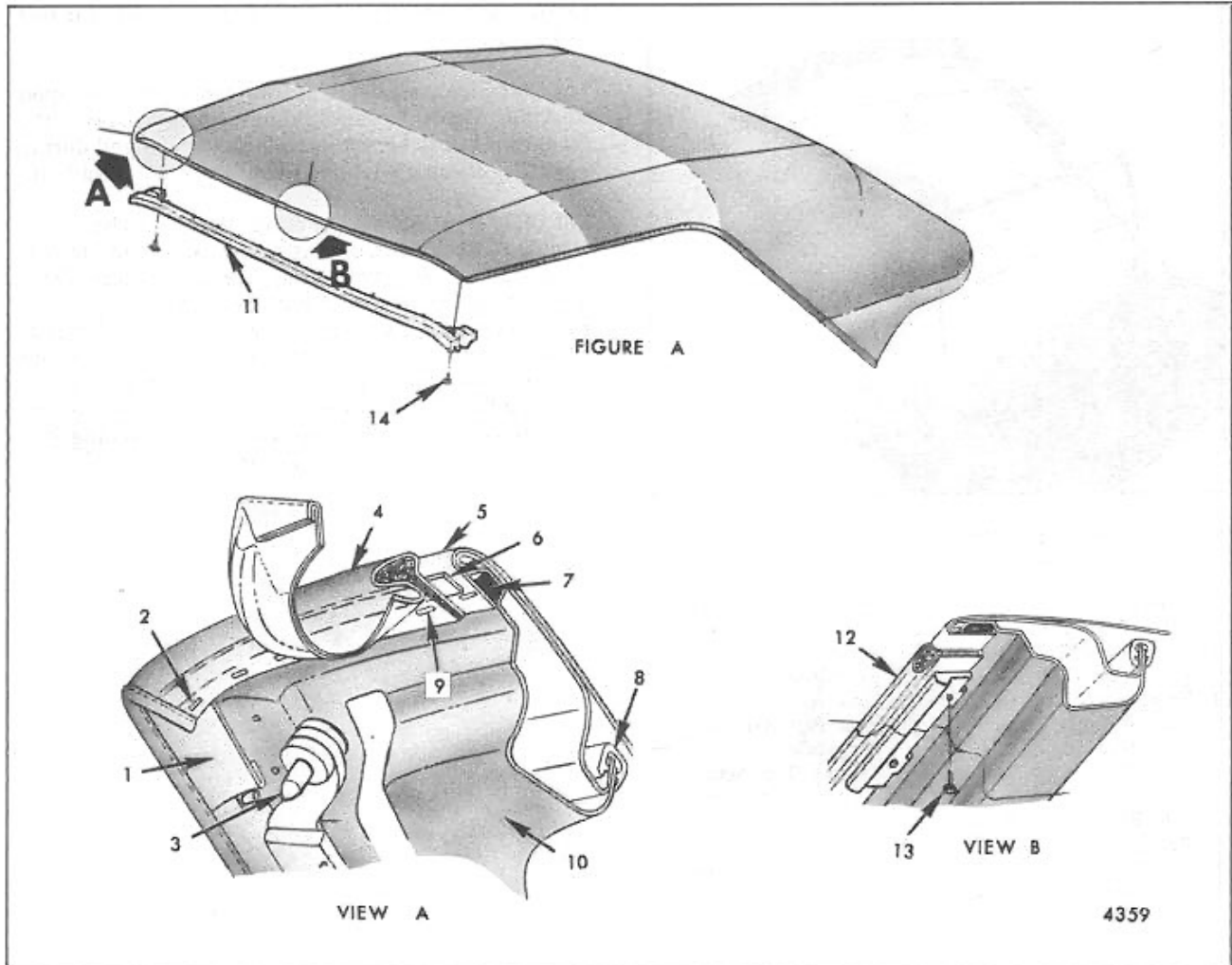

4359

Fig. 3-Front Roof Rail Parts Attachment

- | | | |
|---------------------------------------|---|---|
| 1. Top Cover Corner Retainer | 5. Top Cover | 10. Front Roof Rail |
| 2. Staple Securing Top Cover | 6. Front Weatherstrip to Top Cover Sealer | 11. Front Roof Rail Rear Weatherstrip |
| 3. Front Roof Rail Locating Pin | 7. Tacking Strip | 12. Front Roof Rail to Windshield Header Spacer |
| 4. Front Roof Rail Front Weatherstrip | 8. Pinchweld Finishing Lace | 13. Spacer Attaching Nail |
| | 9. Staple Securing Front Weatherstrip | 14. Attaching Screw |

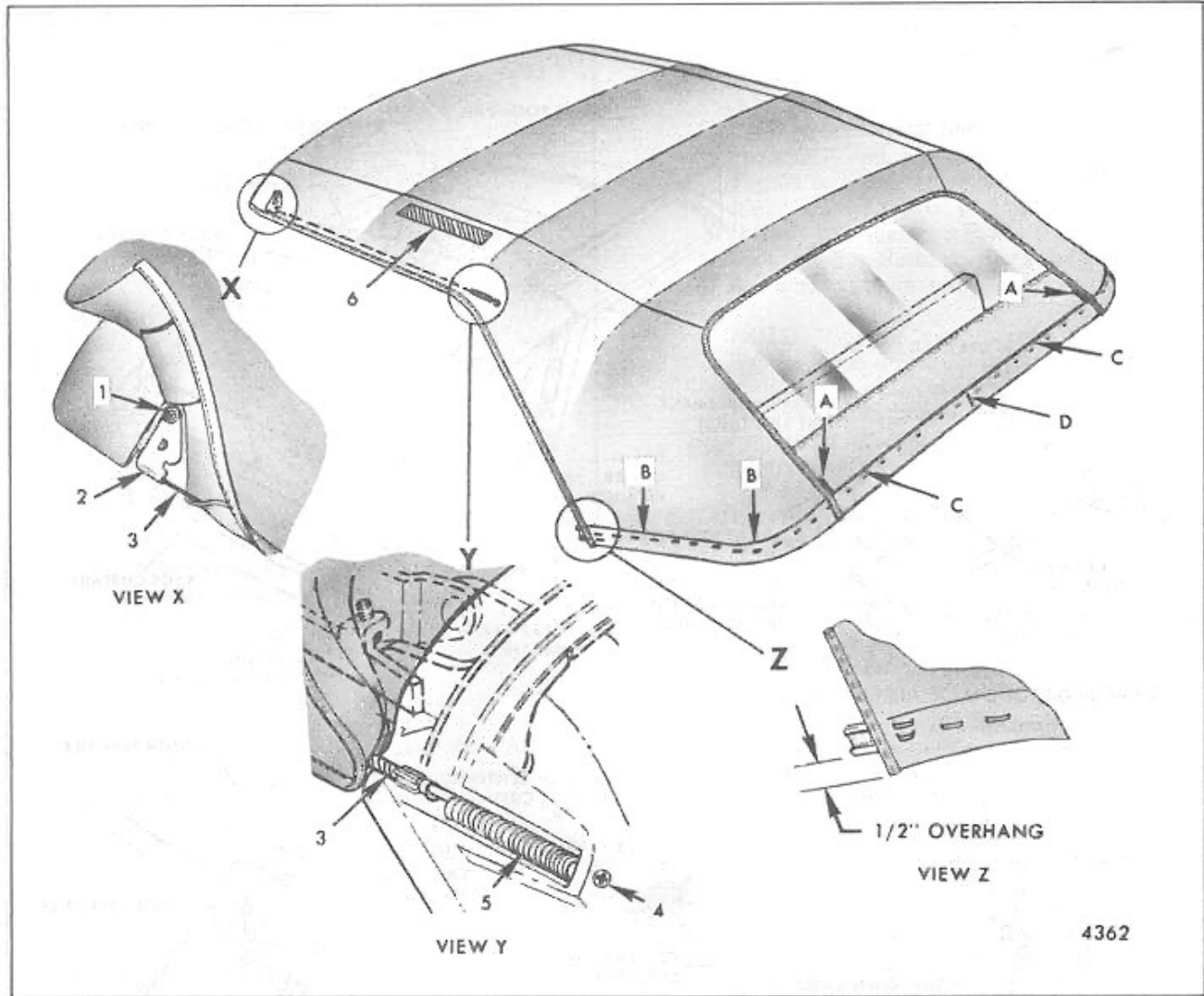

4362

Fig. 4-Hold-Down Cable Attachment and Convertible Top Reference Marking

- | | | |
|----------------------------------|---|--|
| 1. Front Attaching Screw | 3. Hold-Down Cable | 5. Hold-Down Cable Rear Spring |
| 2. Hold-Down Cable Front Bracket | 4. Rear Attaching Screw and Threaded Anchor Nut (Not Shown) | 6. Top Cover to Left Side Quarter Pad Cementing Area |

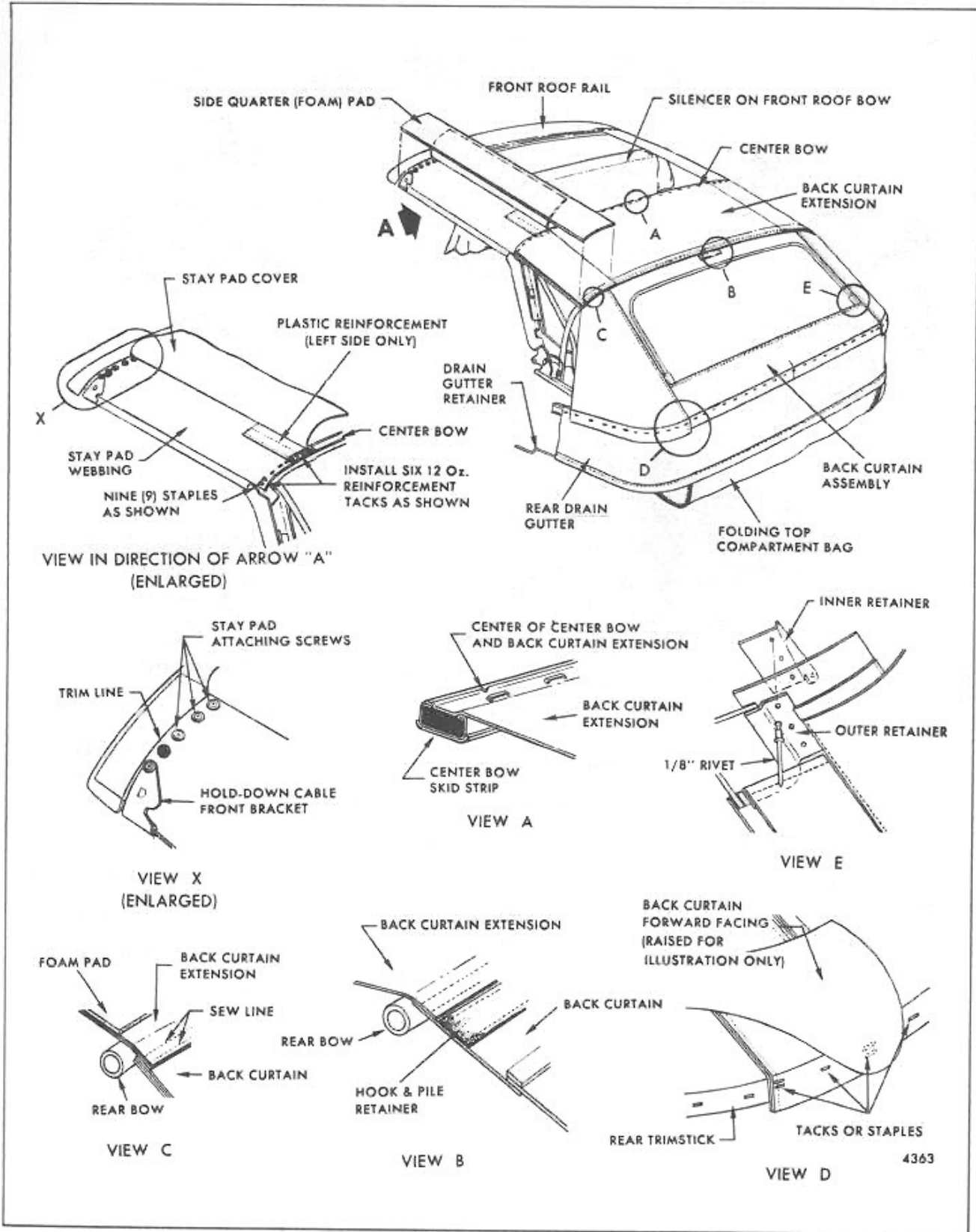

Fig. 5-Back Curtain Assembly Attachment and Reference Marking

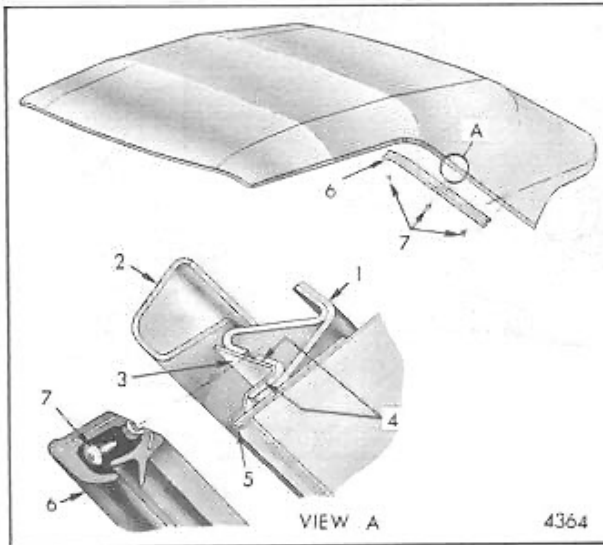

Fig. 6-Side Roof Rail Rear Weatherstrip and Quarter Retainer Attachment

1. Side Roof Outer Rear Rail
2. Side Roof Inner Rear Rail
3. Top Cover Rear Quarter Retainer (Flap)
4. Cementing Surfaces for Retainer
5. Retainer Seam Aligned With Outer Rear Rail
6. Side Roof Rail Rear Weatherstrip
7. Attaching Screw

CAUTION: Control links are under spring tension and must be detached with care to avoid personal injury and/or damage to trim material. For detachment instructions see: "Back Window Guide Control Link and Spring Removal and Installation" (Fig. 19).

4. With top lowered half-way, remove side roof rail rear weatherstrips. Mark reference locations of quarter retainers on side rails (Fig. 6) and detach cemented retainers from side rails.
5. Prepare center bow, rear trimstick and rear gutter assemblies for raising above body belt line as follows:
 - A. With front roof rail several inches above windshield header, remove lower rear bolt (Item "B", Fig. 7) securing trimstick to main hinge on each side. Bolt is removable toward inside of body. Welded anchor nut remains on trimstick.
 - B. In rear compartment, detach gutter retaining rod from attaching clips, or detach clips from body (Fig. 14). Use care to prevent puncturing or tearing gutter during detachment. A total of five attaching clips are located as follows: one on each side of rear compartment lid hinges and one at rear center. Then detach each end of retaining rod from body by moving rod rearward.
 - C. With top lowered about half-way, remove front bolt and nut on each side (Item "A", Fig. 7) securing center bow assembly to main hinge. Bolt enters through bushing and threads into main hinge. Bolt is then secured with lock nut. Bushing is retained in outer rail and contacts main hinge.

NOTE: In some cases, access to bolt may require some deflection of quarter upper rear sealing strip which is metal reinforced and can be restored to proper alignment. Also, avoid losing nut or bolt behind trim by blocking adjacent openings with shop towels.
6. Lift rear trimstick, center bow and gutter assemblies as follows:
 - A. On one side of body, spring trimstick, center bow and gutter assembly inward. Check and position gutter retaining rod and trimstick to assure that they are clear for removal.
 - B. Lift trimstick, center bow and gutter assembly forward and upward as shown in Figure 8.
 - C. Duplicate lifting operation on opposite side of body, and position center bow, rear trimstick and gutter assembly on protected rear deck of car as shown in Figure 9.
7. With suitable marking tool, such as pointed felt tipped pen, or tailor's chalk, accurately mark reference lines on top trim material as follows:
 - A. Vertical edge references of top cover on back curtain at trimstick (Item "A", Fig. 4).
 - B. Upper edge of trimstick on top cover. Press on trim material to determine accurate position of trimstick before marking (Item "B", Fig. 4).
 - C. Upper edge of trimstick on exposed portion of back curtain (Item "C", Fig. 4).
 - D. Center mark on trimstick and on back curtain (Item "D", Fig. 4). If none is present, make one.
8. With staple removing tool, such as narrow screwdriver, detach both sides of top cover from trimstick. Pull top cover upward, and complete marking upper edge reference of trimstick on back curtain (Fig. 10).

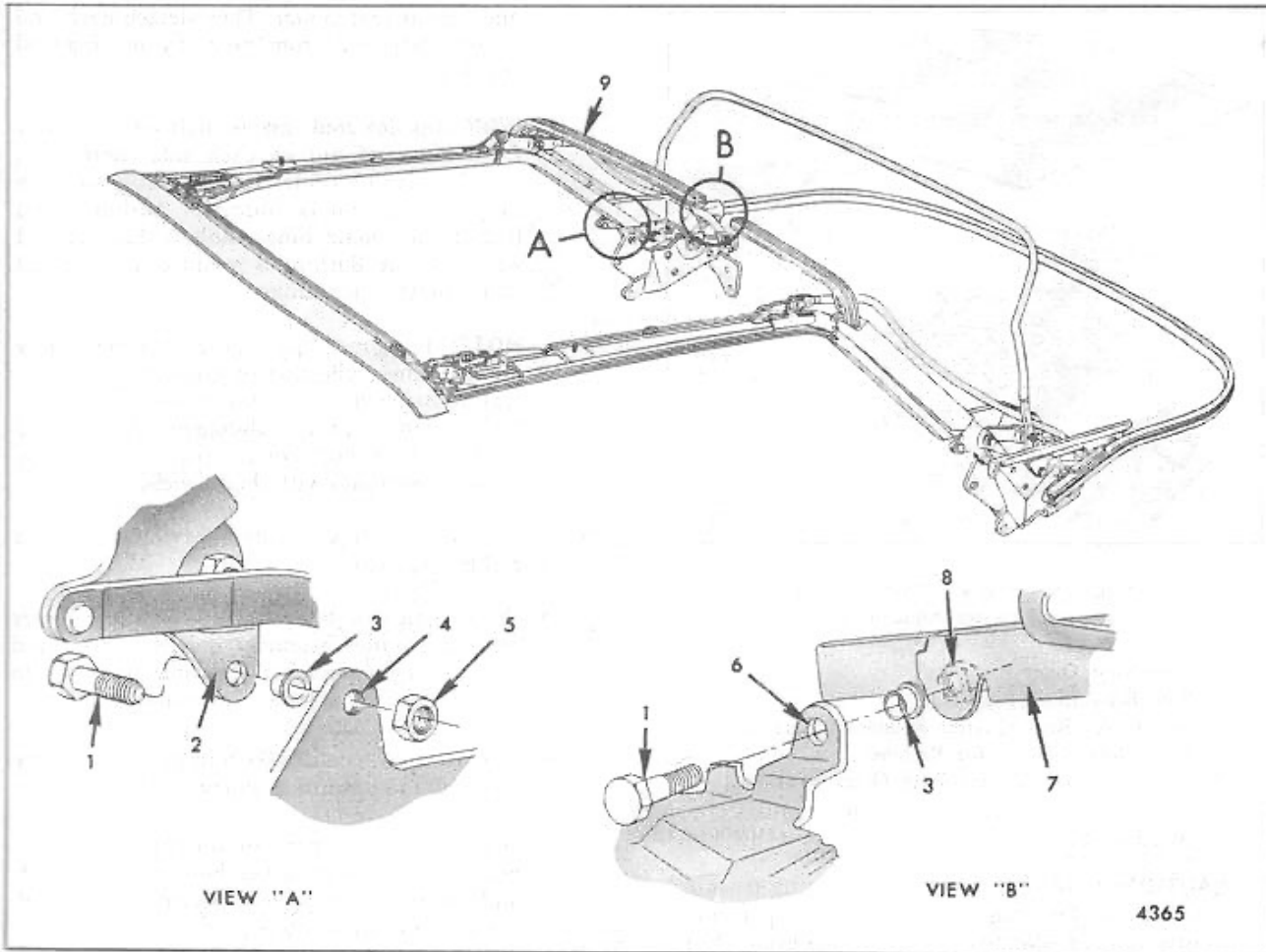

Fig. 7-Center Bow Assembly and Rear Trimstick Attachment

- | | | | |
|--|--------------------------------|---|-----------------------------------|
| 1. Attaching Bolt | 3. Bushing | 6. Main Hinge | 8. Anchor Nut (Part of Trimstick) |
| 2. Side Roof Outer Rear Rail (Part of Center Bow Assembly) | 4. Threaded Hole in Main Hinge | 7. Rear Trimstick (Part of Center Bow Assembly) | 9. Center Bow |
| | 5. Lock Nut | | |



Fig. 8-Lifting Rear Trimstick From Body



Fig. 9-Rear Trimstick on Rear Deck of Car

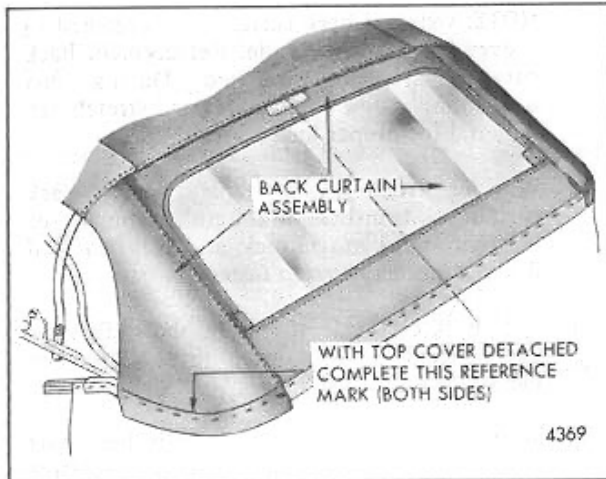

Fig. 10-Completing Reference Marking On Back Curtain

9. Pull top cover upward and remove hold-down cable from top cover pocket on each side leaving rear of cable attached (Fig. 4).
10. Detach and remove top cover as follows:
 - A. Detach top cover rear listing from center bow. Turn rear of top cover forward for access to rear listing (Item "B", Fig. 11).
 - B. Detach top cover front listing from front roof bow. Turn front of top cover rearward for access to front listing (Item "A", Fig. 11).
 - C. Detach top cover where cemented to side stay pads on left side between front and center roof bows (Item "6", Fig. 4).
11. Detach and remove back curtain assembly as follows:
 - A. Detach side quarter foam pad from back curtain extension up to center bow (Fig. 5). If pad(s) are damaged during removal, they should be replaced with equivalent soft, foam rubber material. Use sharp blade, like razor, with care and cut cemented bond while gently lifting foam pad.
 - B. Mark center on back curtain and on adjacent folding top parts as follows:
 1. At top: On back curtain extension and on center roof bow.
 2. At bottom: On back curtain lower inner valance and on gutter material at trimstick.
 - C. Detach back curtain from rear trimstick. Note how folded material is secured below back window sides (Fig. 5).

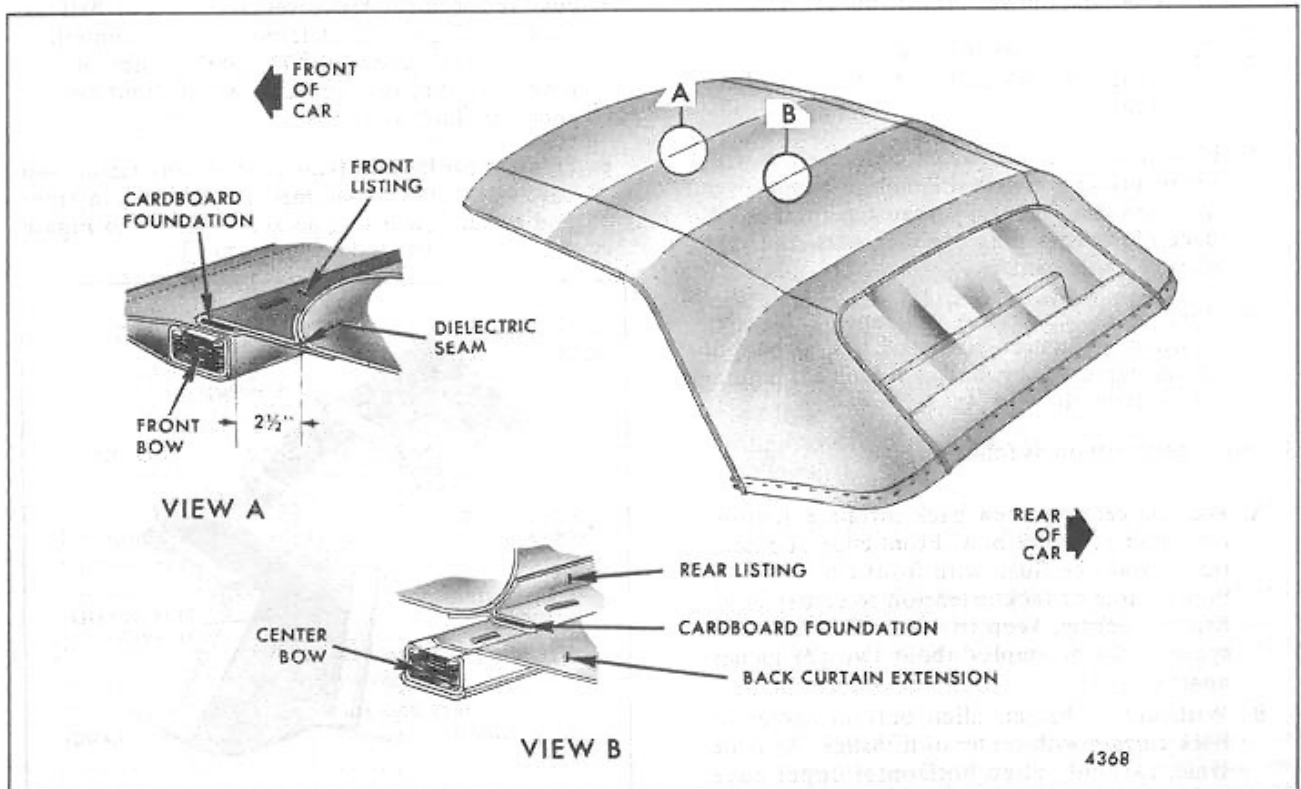

Fig. 11-Top Cover Attachment At Front And Center Roof Bows

- D. Detach back curtain extension from center bow and remove back curtain assembly.

Installation

1. Since original top cover and back curtain are being replaced, carefully and uniformly cut away bottom of original top cover and back curtain along rear trimstick upper reference marks (Figs. 4 and 10).
2. Transfer reference markings from original back curtain and top cover to replacement parts as follows:
 - A. Lay new back curtain flat on clean surface with inside face down. Position original back curtain over new one matching corners of back window openings. Carefully position trim material flat in all directions.
 - B. With back window openings in alignment, accurately transfer trimstick reference to bottom of new back curtain by following along lower cut valance of original back curtain. Use a suitably pointed and legible marking pencil or tailor's chalk (Item "C", Figs. 4 and 10).
 - C. Transfer center reference mark from original back curtain to new one at top (on extension) and at bottom (on valance) (Item "D", Fig. 4).
 - D. Transfer top cover vertical edge reference from original back curtain to new one (Item "A", Fig. 4).
 - E. Place new top cover flat on clean surface with inner surface down. Position original top cover over new one. Carefully align top cover sides, back window opening upper corners, and rear quarter upper corners.
 - F. With both covers in alignment, transfer trimstick references, right and left, to bottom of new top cover by marking along cut bottom edges (Item "B", Fig. 4).
3. Install back curtain as follows:
 - A. Position center of new back curtain extension on center of center bow. Front edge of extension should be flush with front rib of center bow. Staple or tack extension to center bow. Start at center, keep trim material flat, and space tacks or staples about two (2) inches apart (Fig. 5).
 - B. With aid of helper, align bottom center of back curtain with center of trimstick. At same time, carefully align horizontal upper edge reference mark at upper edge of trimstick (Fig. 4).

NOTE: Original back curtains are stretched to a degree upon installation. Replacement back curtains are not stretched. During this operation, allow for uniform stretch in material for proper final appearance.

- C. Working from center, staple or tack back curtain to trimstick. Maintain alignment of reference mark at trimstick, and keep material flat to trimstick between fasteners.
 - D. Fold back each side of curtain, shown in View "D", Figure 5, and install three staples or tacks at this location.
 - E. Space staples or tacks about two inches apart (about 40 tacks or staples). Avoid excessive stretching of material (Fig. 5).
 - F. Allow 1/2 inch of back curtain to over-hang rear trimstick. Using scissors, cut off excess material beyond 1/2 inch over-hang (View "Z", Fig. 4).
4. Cement original or replacement side quarter (foam) pad (Fig. 5) between center bow and rear bow on each side. If pad(s) from center to rear bow were damaged upon removal, replace them with equivalent foam rubber material.
 5. Fold replacement top cover assembly in half as shown in Figure 12. Determine precise centerline of top cover and carefully mark center of top cover on listings for center bow and front bow as shown in illustration.
 6. Transfer cardboard foundations from original top cover, or install replacement foundations in front and center bow listing pockets as shown in Figure 11.

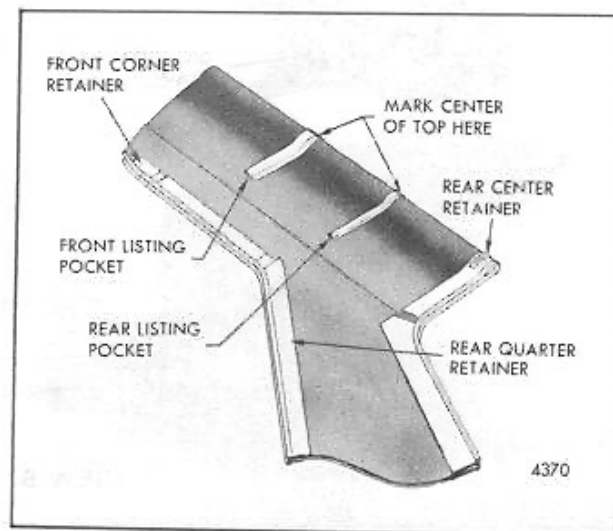

Fig. 12-Determining Center of Top Cover

7. Position center of top cover rear listing on center bow and staple or tack in place. Space fasteners about two (2) inches apart (Fig. 11).
8. Insert hold-down cables in top cover. Use a length of welding rod to facilitate insertion (Fig. 4).
9. With aid of helper, install top cover as follows:
 - A. Align top cover at rear vertical reference mark and at trimstick horizontal reference (Items "A" and "C", Fig. 4). With helper holding trim in aligned position, double tack or staple at this location using 12 ounce tacks or equivalent staples.

NOTE: Original top covers are stretched to a degree upon installation. Replacement top covers are not stretched. During installation, allow for uniform stretch in new cover for proper final appearance.
 - B. Apply trim cement to lower area of side roof rear rail and to top cover quarter retainer (flap). Center top (laterally) by aligning horizontal reference on each side at trimstick. Secure quarter retainer (flap) at bottom. Also, double staple or tack top cover at front of trimstick (Fig. 6 and View "Z", Fig. 4) using 12 ounce tacks or equivalent staples.
 - C. Align top cover horizontal reference at center (in accordance with steps A and B above) and staple or tack in place. Work forward and rearward from center. Keep material in alignment and flat. Avoid stretching. Space staples or tacks about two (2) inches apart.
 - D. Trim off excess material beyond 1/2 inch over-hang (Fig. 4).

NOTE: If diagnosis prior to top cover removal revealed particular conditions (Such as: Loose material, etc.) the conditions can be corrected by adjusting top cover on trimstick in steps A, B and C above.
10. Position five (5) clips on gutter retaining rod. Position clips according to Figure 14 as follows: One on each side of rear compartment lid hinge and one at rear center.
11. Position rear trimstick, center bow and gutter assembly into body in reverse order of removal. With top half-lowered, start one end of trimstick and gutter into body as shown in Figure 8, then position opposite end into body.
12. Secure trimstick, center bow and gutter assembly to body as follows:
 - A. Raise top to up position. Secure back window guide control links. For attachment of control links see: "Back Window Guide Control Link Removal and Installation" (Fig. 19).
 - B. Raise top several inches above windshield header. Install bushing in main hinge, align trimstick to main hinge attaching holes and install trimstick attaching bolts (View "B", Fig. 7). Use care to avoid dropping bolt. To avoid losing bolt, block openings at wheel-house with several shop towels.
 - C. Lower top half-way as shown in Figure 8. With bushing properly positioned in each outer rail, install attaching bolts (View "A", Fig. 7) securing outer rail to main hinge. Each bolt threads into hinge and is secured with lock nut.
 - D. Secure rear gutter retaining rod and clips to body as shown in Figure 14.
13. Secure top cover front listing to front roof bow as follows (Fig. 11):
 - A. Check alignment of cardboard foundation at front listing pocket as shown in illustration. Foundation must be at front of listing pocket as shown.
 - B. Center listing and foundation on center of front bow.
 - C. Secure listing in place with staples or tacks spaced about two (2) inches apart. Distance from end of foundation to center of dielectric seam should be about 2-1/2 inches as shown in View "A", Figure 11.
14. With top several inches off windshield header, position and secure hold-down cables at front (Fig. 4). Position bracket by inserting tab and secure bracket with screw, then secure metal tab.
15. Align and secure top cover at front roof rail as follows:
 - A. Raise top and lock to windshield header.
 - B. With aid of helper, pull top cover forward and down to remove wrinkles and irregularities. Mark reference of front edge of front roof rail on top cover.
 - C. Unlock front roof rail, apply cement to attaching surfaces at front of cover and on front roof rail (Fig. 13). Apply cement to underside of front roof rail. This includes tacking strip and both corners.

D. Secure top cover to front roof rail according to reference marks above, and check appearance of top cover by locking top to windshield header. Adjust top cover by drawing material forward and/or laterally as required for proper alignment and appearance, and secure with cement. Front corner retainers (flaps) secure only to front roof rail.

NOTE: For best results of top installation and appearance, step 15D should be done in conjunction with step 16 before securing either permanently.

16. With top locked to windshield header, cement, align and secure upper areas of quarter retainers (flaps) to side roof outer rear rails. Re-check alignment of top cover over center bow, and align quarter retainer seams with edges of side roof rear rails. Remove all fullness from rear of top cover (Fig. 6). A forward draw on cover outer sides will aid this operation. Align quarter retainers to each rear rail and cement securely in place. Top cover binding at quarter retainers should not curl away from rear rail.
17. Lower top and secure top cover to front roof rail trimstick with staples or tacks spaced about two inches apart. Remove excess top material along rear of trimstick.
18. Using weatherstrip adhesive at outer ends, position and secure rear weatherstrip on front roof rail. Use outer attaching screw holes for locating purposes (Fig. 3).
19. Position, secure and seal front roof rail front weatherstrip (Fig. 3). Front weatherstrip must be properly positioned and sealed as shown in illustration.
20. Install and align side roof rail rear weatherstrips. Adjust rear weatherstrips forward for butt fit when top is locked at windshield header. After tightening upper two screws, lower top part way to tighten lower screw.

IMPORTANT: Side roof rail front weatherstrips are not designed to be adjusted "fore or aft". For improved contact at upper front corners, reposition windshield pillar weatherstrips upward.

21. Remove all protective covers and clean up.

FOLDING TOP COVER (LESS BACK CURTAIN)

Removal

IMPORTANT: Before removal operations are started, check and specifically note alignment of top cover.

Conditions, such as: wrinkles, draws, excess material, etc., can be corrected by adjusting trim material during assembly operations.

1. Apply protective covers to car as follows:
 - A. On rear deck section of car, particularly area adjacent to quarter belt finishing moldings, apply heavy padded cover to protect moldings and paint finish. Mask securely in place (Fig. 8).
 - B. On interior trim, floor and hood, use conventional covers.
2. With top lowered, detach top cover at front roof rail as follows (Fig. 3):
 - A. Remove front roof rail front weatherstrip.
 - B. Detach front roof rail rear weatherstrip at outer ends.
 - C. Detach top cover from front roof rail. Use care to avoid disturbing silencer attachment at front roof rail (Fig. 13).
 - D. With top a short distance above windshield header, remove attaching screws, unbend metal tabs, and detach hold-down cables at front (Fig. 4).
3. With top raised, detach guide control links from lower corners of back window, slip compartment bag over links and lay links on floor.

CAUTION: Control links are under spring tension and must be detached with care to avoid personal injury and/or damage to trim material. For detachment instructions see: "Back Window Guide Control Link and Spring Removal and Installation" (Fig. 19).
4. With top lowered half-way, remove side roof rail rear weatherstrips. Mark reference locations of quarter retainers on side rails (Fig. 6) and detach cemented retainers from side rails.
5. Detach center bow, rear trimstick and rear gutter assemblies for raising above body belt line as follows:
 - A. With front roof rail several inches above windshield header, remove lower rear bolt (Item "B", Fig. 7) securing trimstick to main hinge on each side. Bolt is removable toward inside of body. Welded anchor nut remains on trimstick.
 - B. In rear compartment, detach gutter retaining rod from attaching clips or detach clips from

body. Use care to prevent puncturing or tearing gutter during detachment. A total of five attaching clips are located as follows; one on each side of rear compartment lid hinges and one at rear center. Then detach each end of retaining rod from body by moving rod rearward.

- C. With top lowered about half-way, remove front bolt and nut on each side (Item "A", Fig. 7) securing center bow assembly to main hinge. Bolt enters through bushing and threads into main hinge. Bolt is then secured with lock nut. Bushing is retained in outer rail and contacts main hinge.
- NOTE:** In some cases, access to bolt may require some deflection of quarter upper rear sealing strip which is metal reinforced and can be restored to proper alignment. Also, avoid losing nut or bolt behind trim by blocking adjacent openings with shop towels.
6. Lift rear trimstick, center bow and gutter assemblies from body as follows:
 - A. On one side of body, spring trimstick, center bow and gutter assembly inward. Check and position gutter retaining rod and trimstick to assure that they are clear for removal.
 - B. Lift trimstick, center bow and gutter assembly upward and forward as shown in Figure 8.
 - C. Duplicate lifting operation on opposite side of body, and position center bow, rear trimstick and gutter assembly on protected rear deck of car as shown in Figure 9.
 7. With suitable marking tool, such as pointed felt tipped pen, or tailor's chalk, accurately mark reference lines on top trim material as follows:
 - A. Vertical edge references of top cover on back curtain at trimstick (Item "A", Fig. 4).
 - B. Upper edge of trimstick on top cover. Press on trim material to determine accurate position of trimstick before marking (Item "B", Fig. 4).
 8. With staple removing tool, such as narrow screwdriver, detach both sides of top cover from trimstick.
 9. Pull top cover upward and remove hold-down cable from top cover pocket on each side leaving rear of cable attached (Fig. 4).
 10. Detach and remove top cover as follows:

- A. Detach top cover rear listing from center bow. Turn rear of top cover forward for access to rear listing (Item "B", Fig. 11).
- B. Detach top cover front listing from front roof bow. Turn front of top cover rearward for access to front listing (Item "A", Fig. 11).
- C. Detach top cover where cemented to side quarter (stay) pad on left side between front and center roof bows (Item "6", Fig. 4).

Installation

1. Since original top cover is being replaced, carefully and uniformly cut off bottom of original top cover along trimstick upper reference mark.
2. Place new top cover flat on clean surface with inner surface down. Position original top cover over new one and reference mark as follows (Fig. 4):
 - A. Carefully align top cover sides.
 - B. Align back window opening upper corners.
 - C. Align rear quarter upper corners.
 - D. With both covers in alignment, transfer trimstick references, right and left, to bottom of new top cover by marking along cut bottom edges (Item "B", Fig. 4).
3. Fold replacement top cover in half as shown in Figure 12. Determine precise centerline of top cover and carefully mark center of top cover on listings for center bow and front bow as shown in illustration.
4. Transfer cardboard foundations from original top cover, or install replacement foundations in front bow and center bow listing pockets as shown in Figure 11.
5. Position center of top cover rear listing on center of center bow and staple or tack in place. Space fasteners about two inches apart (Fig. 11).
6. Insert hold-down cables in top cover. Use a length of welding rod to facilitate insertion (Fig. 4).
7. With aid of helper, install top cover as follows:
 - A. Align top cover at rear vertical reference mark and at trimstick horizontal reference. With helper holding trim in aligned position, double tack or staple at this location using 12 ounce tacks or equivalent staples.

NOTE: Original top covers are stretched to a degree upon installation. Replacement top covers are not stretched. During installation, allow for uniform stretch in new cover for proper final appearance.

- B. Apply trim cement to lower area of side roof rear rail and to top cover quarter retainer (flap). Center top (laterally) by aligning horizontal reference on each side at trimstick. Secure quarter retainer (flap) and seam at bottom. Also, double staple or tack top cover at front of trimstick (Fig. 6 and View "Z", Fig. 4) using 12 ounce tacks or equivalent staples.
 - C. Align top cover horizontal reference at center (in accordance with steps A and B above) and staple or tack in place. Work forward and rearward from center. Keep material in alignment and flat. Space staples or tacks about two inches apart.
 - D. Trim off excess material beyond 1/2 inch over-hang (Fig. 4).
- NOTE:** If diagnosis prior to top cover removal revealed particular conditions (Such as loose material, etc.) the conditions can be corrected by adjusting top cover on trimstick in steps A, B and C above.
8. Position five (5) clips on gutter retaining rod. Position clips according to Figure 14 as follows: One on each side of rear compartment lid hinge and one at rear center.
 9. Position rear trimstick, center bow and gutter assembly into body in reverse order of removal. With top half lowered, start one end of trimstick and gutter into body as shown in Figure 8 and then position opposite end into body.
 10. Secure trimstick, center bow and gutter assembly to body as follows:
 - A. Manually, raise top to up position. Secure back window guide control links. For attachment of control links, see: "Back Window Guide Control Link Removal and Installation" (Fig. 19).
 - B. Raise top several inches above windshield header. Install bushing in main hinge, align trimstick to main hinge attaching holes and install trimstick attaching bolts (View "B" Fig. 7). Use care to avoid dropping bolt. To avoid losing bolt, block openings at wheel-house with several shop towels.
 - C. Lower top half-way as shown in Figure 8. With bushing properly positioned in each

outer rail, install attaching bolts (View "A", Fig. 7) securing outer rail to main hinge. Each bolt threads into hinge and is secured with lock nut.

- D. Secure gutter retaining rod and clips to body (Fig. 14).
11. Secure top cover front listing to front roof bow as follows (Fig. 11):
 - A. Check alignment of cardboard foundation at front of listing pocket as shown in illustration. Foundation must be at front of listing pocket as shown.
 - B. Center listing and foundation on center of front bow.
 - C. Secure listing in place with staples or tacks spaced about two (2) inches apart. Distance from end of foundation to center of dielectric seam should be about 2-1/2 inches as shown in View "A", Figure 11.
12. With top several inches off windshield header, position and secure hold-down cables at front (Fig. 4). Position bracket by inserting tab and secure bracket with screw.
13. Align and secure top cover at front roof rail as follows:
 - A. Raise top and lock to windshield header.
 - B. With aid of helper, pull top cover forward and down to remove wrinkles and irregularities. Mark reference of front edge of front roof rail on top cover.
 - C. Unlock front roof rail, apply cement to attaching surfaces at front of cover and on front roof rail (Fig. 13). Apply cement to underside of front roof rail. This includes trimstick and both corners.
 - D. Secure top cover to front roof rail according to reference marks above, and check appearance of top cover by locking top windshield header. Adjust top cover by drawing material forward and/or laterally as required for proper alignment and appearance and secure with cement. Front corner retainers (flaps) secure only to front roof rail.

NOTE: For best results of top installation and appearance, step 13D should be done in conjunction with step 14 before securing either permanently.
14. With top locked to windshield header, cement, align and secure upper areas of quarter retainers

(flaps) to side roof outer rear rails. Re-check alignment of top cover over center bow and align quarter retainer seams with edges of side roof rear rails. Remove all fullness from rear of top cover (Fig. 6). A forward draw on cover outer sides will aid this operation. Align quarter retainers to each rear rail and cement securely in place. Top cover binding at quarter retainers should not curl away from rear rail.

15. Lower top and secure top cover to front roof rail trimstick with staples or tacks spaced about two inches apart. Remove excess top material along rear of trimstick.
16. Using weatherstrip adhesive at outer ends, position and secure front roof rail rear weatherstrip. Use outer attaching screw holes for locating purposes (Fig. 3).
17. Position, secure and seal front roof rail front weatherstrip (Fig. 3). Front weatherstrip must be properly positioned and sealed as shown in illustration.
18. Install and align side roof rail rear weatherstrips. Adjust rear weatherstrips forward for butt fit when top is locked at windshield header. After tightening upper one or two screws, lower top part way to tighten lower screw.

IMPORTANT: The side roof rail front weatherstrips are not designed to be adjusted "fore or aft". For improved contact at upper front corners, reposition windshield pillar weatherstrip upward.
19. Remove protective covers, shop towels, if used, and clean up.

BACK CURTAIN ASSEMBLY (LESS TOP COVER)

Removal

IMPORTANT: Before removal operations are started, check and specifically note alignment condition of back curtain. Conditions, such as: wrinkles, draws, excess material, etc., can be corrected by adjusting trim material during assembly operations.

1. Apply protective covers to car as follows:
 - A. On rear deck section of car, particularly area adjacent to quarter belt finishing moldings, apply heavy padded cover to protect moldings and paint finish. Mask securely in place (Fig. 8).
 - B. On interior trim and floor, use conventional covers.

2. With top raised, detach guide control links from lower corners of back window, slip compartment bag over links and lay links on floor.

CAUTION: Control links are under spring tension and must be detached with care to avoid personal injury and/or damage to trim material. For detachment instructions see: "Back Window Guide Control Link and Spring Removal and Installation" (Fig. 19).

3. With top lowered half-way, remove side roof rail weatherstrips. Mark reference locations of quarter retainers on side rails (Fig. 6) and detach cemented retainers from side rails.
4. Prepare center bow, rear trimstick and rear gutter assemblies for lifting above body belt line as follows:
 - A. With front roof rail several inches above windshield header, remove lower rear bolt (View "B", Fig. 7) securing trimstick to main hinge on each side. Bolt is removable toward inside of body. Welded anchor nut remains on trimstick.
 - B. In rear compartment, detach gutter retaining rod from attaching clips or detach clips from body. Use care to prevent puncturing or tearing gutter during detachment. A total of five attaching clips are located as follows; one on each side of rear compartment lid hinges and one at rear center. Then detach each end of retaining rod from body by moving rod rearward.
 - C. With top lowered about half-way, remove front bolt and nut on each side (View "A", Fig. 7) securing center bow assembly to main hinge. Bolt enters through bushing and threads into main hinge. Bolt is then secured with lock nut. Bushing is retained in outer rail and contacts main hinge.

NOTE: In some cases, access to bolt may require some deflection of quarter upper rear sealing strip which is metal reinforced and can be restored to proper alignment. Also, avoid losing nut or bolt behind trim by blocking adjacent openings with shop towels.

5. Lift rear trimstick center bow, and gutter assemblies from body as follows:
 - A. On one side of body, spring trimstick, center bow and gutter assembly inward. Check and position gutter retaining rod and trimstick to assure that they are clear for removal.

- B. Lift trimstick, center bow and gutter assembly forward and upward as shown in Figure 8.
 - C. Duplicate lifting operation on opposite side of body and position center bow, rear trimstick and gutter assembly on protected rear deck of car as shown in Figure 9.
6. With suitable marking tool, such as pointed felt tipped pen, or tailor's chalk, accurately mark reference lines on top trim material as follows:
 - A. Vertical edge references of top cover on back curtain at trimstick (Item "A", Fig. 4).
 - B. Upper edge of trimstick on top cover. Press on trim material to determine accurate position of trimstick before marking (Item "B", Fig. 4).
 - C. Upper edge of trimstick on exposed portion of back curtain (Item "C", Fig. 4).
 - D. Center mark on trimstick and on back curtain (Item "D", Fig. 4). If none is present, make one.
 7. With staple removing tool, such as narrow screwdriver, detach both sides of top cover from trimstick. Pull top cover upward, and complete marking upper edge reference of trimstick on back curtain (Fig. 10).
 8. Lift top cover upward and detach hold-down cable at rear (Fig. 4).
 9. Detach top cover rear listing from center bow. Turn rear of top cover forward for access to rear listing (Item "B", Fig. 11).
 10. Detach and remove back curtain assembly as follows:
 - A. Detach side quarter foam pad from back curtain extension up to center bow (Fig. 5). If pad(s) are damaged during removal, replace them with equivalent soft, foam rubber material. Use sharp blade, like razor, with care and cut cemented bond while gently lifting foam pad.
 - B. Mark center on back curtain and on adjacent parts as follows:
 1. At top: On back curtain extension and on center roof bow.
 2. At bottom: On back curtain lower inner valance and on gutter material at trimstick.
 - C. Detach back curtain from rear trimstick. Note how folded material is secured below back window sides (Fig. 5).

- D. Detach back curtain extension from center bow and remove back curtain assembly.

Installation

1. Since original back curtain is being replaced, carefully and uniformly cut away bottom of original back curtain along rear trimstick upper reference marks (Figs. 10 and 4).
2. Transfer reference markings from original back curtain to replacement back curtain as follows:
 - A. Lay new back curtain flat on clean surface with inside face down. Position original back curtain over new one matching corners of back window openings. Carefully position trim material flat in all directions.
 - B. With back window openings in alignment, accurately transfer trimstick reference to bottom of new back curtain by following along lower cut valance of original back curtain. Use a suitably pointed and legible marking pencil or tailor's chalk. (Item "C", Fig. 4 and 10).
 - C. Transfer center reference mark from original back curtain to new one at top (on extension) and at bottom (on valance) (Item "D", Fig. 4).
 - D. Transfer top cover vertical edge reference from original back curtain to new one (Item "A", Fig. 4).
3. Install back curtain as follows:
 - A. Position center of new back curtain extension on center of center bow. Front edge of extension should be flush with front rib of center bow. Staple or tack extension to center bow. Start at center, keep trim material flat, and space tacks or staples about two (2) inches apart (Fig. 5).
 - B. With aid of helper, align bottom center of back curtain with center of trimstick. At same time, carefully align horizontal, upper edge reference mark at upper edge of trimstick (Fig. 5).

NOTE: Original back curtains are stretched to a degree upon installation. Replacement back curtains are not stretched. During this operation, allow for uniform stretch in material by adjusting horizontal reference for proper final appearance.

 - C. Working from center, staple or tack back curtain to trimstick. Maintain alignment of reference mark at trimstick, and keep material flat to trimstick between fasteners.

- D. Fold back each side of curtain, shown in Item "D", Figure 5, and install three staples or tacks at this location.
 - E. Space staples or tacks about two inches apart (about 40 tacks or staples). Avoid excessive stretching of material.
 - F. Allow 1/2 inch of back curtain to over-hang rear trimstick. Using scissors, cut off excess material beyond 1/2 inch over-hang (Fig. 4).
4. Cement original or replacement side quarter (foam) pad (Fig. 5) between center bow and rear bow on each side. If pad(s) from center to rear bow were damaged upon removal, replace them with equivalent foam rubber material.
 5. Position center of top cover rear listing on center of center bow and staple or tack in place. Space fasteners about two inches apart (Fig. 11).
 6. Secure hold-down cables at rear (Fig. 4).
 7. With aid of helper, install top cover as follows:
 - A. Align top cover at rear vertical reference mark and at trimstick horizontal reference (Items "A" and "C", Fig. 4). With helper holding trim in aligned position, double tack or staple at this location using 12 ounce tacks or equivalent staples.
 - B. Apply trim cement to lower area of side roof rear rail and to top cover quarter retainer (flap). Center top (laterally) by aligning horizontal reference on each side at trimstick. Secure quarter retainer (flap) at lower area. Also, double staple or tack top cover at front of trimstick (Fig. 6 and View "Z", Fig. 4) using 12 ounce tacks or equivalent staples.
 - C. Align top cover horizontal reference at center (in accordance with steps A and B above), and staple or tack in place. Work forward and rearward from center. Keep material in alignment and flat. Avoid stretching. Space staples or tacks about two inches apart.
 - D. Trim off excess material beyond 1/2 inch over-hang (Fig. 4).

NOTE: If diagnosis prior to top cover removal revealed particular conditions (Such as: Loose material, etc.), the conditions can be corrected by adjusting top cover on trimstick at this time.
 8. Position five (5) clips on gutter retaining rod. Position clips according to Figure 14 as follows: One clip on each side of rear compartment lid hinges and one at rear center.
 9. Position rear trimstick, gutter, and center bow assembly into body in reverse order of removal. With top half lowered, start one end of trimstick and gutter into body as shown in Figure 8, then position opposite end into body.
 10. Secure trimstick, gutter and center bow assembly to body as follows:
 - A. Raise top to up position. Secure back window guide control links. For attachment of control links, see: "Back Window Guide Control Link Removal and Installation" (Fig. 19).
 - B. Raise top several inches above windshield header. Install bushing in main hinge; align trimstick to main hinge attaching holes; and install trimstick attaching bolts (View "B", Fig. 7). Use caution to avoid dropping bolt. To avoid losing bolt, block openings at wheelhouse with several shop towels.
 - C. Lower top half-way as shown in Figure 8. With bushing properly positioned in each outer rail, install attaching bolts (View "A", Fig. 7) securing outer rail to main hinge. Each bolt threads into hinge and is secured with lock nut.
 - D. Secure gutter retaining rod and clips to body (Fig. 14).
 11. With top locked to windshield header, cement, align and secure upper attaching surfaces of quarter retainers (flaps) to side roof outer rear rails. Align quarter retainer seams with edges of side roof outer rear rails to remove all fullness from rear of top cover (Fig. 6). A forward draw on cover outer sides will aid this operation. Align quarter retainers to each rear rail and cement securely in place. Top cover binding along rear rails should not curl away from rails.
 12. Install and align side roof rail rear weatherstrips. Adjust rear weatherstrips forward for butt fit when top is locked at windshield header. After tightening upper one or two screws, lower top part way to tighten lower screw.

IMPORTANT: Side roof rail front weatherstrips are not designed to be adjusted "fore or aft". For improved contact at upper front corners, position windshield pillar weatherstrips upward.
 13. Remove protective covers and clean up.

FOLDING TOP SILENCER ASSEMBLY

The silencer is serviced as a complete assembly and consists of a section of deadener padding sewn to an inner lining trim cloth. The assembly is located under

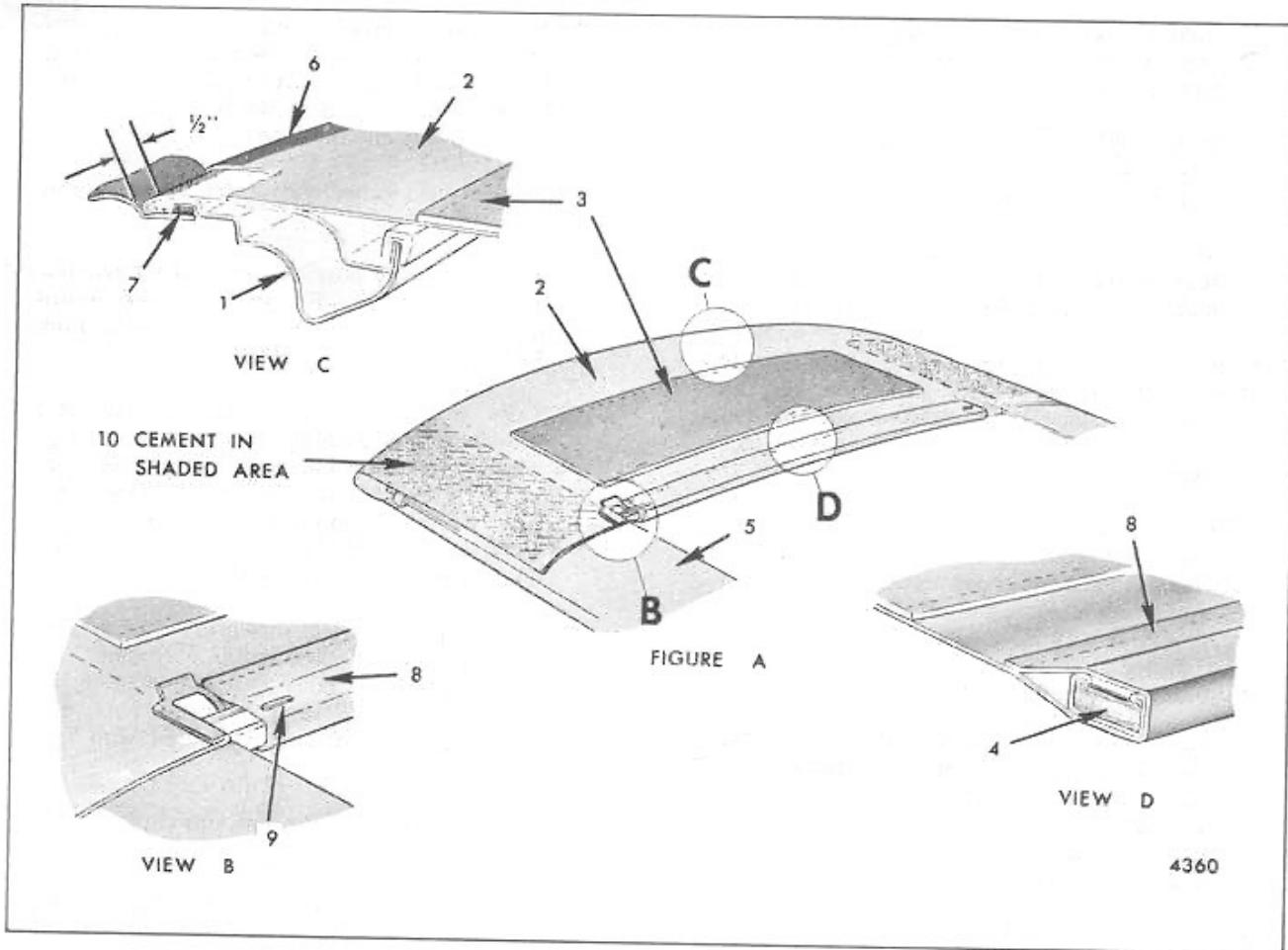

Fig. 13-Folding Top Silencer Assembly Attachment

- | | | |
|---|--|---|
| <ul style="list-style-type: none"> 1. Front Roof Rail 2. Silencer Assembly 3. Deadener Pad 4. Front Roof Bow 5. Side Quarter Padding | <ul style="list-style-type: none"> 6. Trim Cement
Securing Silencer to
Front Rail and
Tacking Strip 7. Front Roof Rail
Tacking Strip | <ul style="list-style-type: none"> 8. Silencer Listing
Pocket 9. Staple 10. Trim Cement in
Shaded Area
Securing Silencer to
Side Quarter Padding |
|---|--|---|

the folding top at the front, and is secured around its perimeter as follows (Fig. 13):

- A. At the front roof rail - Cement and staples
- B. At the front roof bow - Slide-on listing pocket and staples
- C. At side quarter padding - Cement

Removal

1. With top lowered to stacked position, remove front roof rail front weatherstrip. Detach front roof rail rear weatherstrip at outer ends (Fig. 3).
2. Reference mark front edge of front roof rail on top cover. Also place center mark on cover and on masked section of front roof rail.
3. Detach top cover and silencer assembly from front roof rail (staples and cement). Do not detach side quarter padding.
4. Raise top and, with front roof rail several inches above windshield header, detach hold-down cables at front (Fig. 4).
5. Turn back top cover and detach cemented side sections of silencer from side quarter padding (Fig. 13).

6. Detach top cover listing from front roof bow by removing staples (Fig. 11).
7. Remove two attaching screws from bracket at one end of front roof bow and slip silencer assembly pocket from front roof bow.

Installation

1. With deadener padding on top side of assembly, slip pocket of silencer assembly onto front roof bow (Fig. 13). Center silencer between side quarter padding and secure silencer pocket to front roof bow by installing one staple or tack at each outer end as shown.
 2. Secure front roof bow attaching bracket with two attaching screws.
 3. With top lowered, apply trim cement to front roof rail and to silencer as shown in Figure 13. Lock top to windshield header. With silencer centered between side quarter padding pull assembly forward tightly and secure to front edge of front roof rail. Cement only at forward 1/2 inch edge of front roof rail.
 4. Lower top and complete securing forward section of silencer to front roof rail and to tacking strip (Fig. 3). Space staples or tacks four inches apart. Trim off excess material beyond tacking strip.
 5. With top raised and locked at windshield header, apply trim cement sparingly to side quarter padding and to side sections of silencer. Position sides of silencer on padding and on front roof bow and press into place.
 6. Position and center top cover listing and cardboard foundation on front roof bow as shown in Figure 11 and secure in place with staples or tacks spaced about two inches apart.
- IMPORTANT:** Distance between center of dielectric seam and edge of foundation must be about 2-1/2 inches as shown.
7. Turn top cover forward and, with top raised several inches, position hold-down cables and secure in place (Fig. 4).
 8. Apply trim cement to front roof rail, top cover and top cover corner retainers (flaps). With front roof rail several inches off windshield header, align top cover reference marks with front roof rail and secure top cover in place.
 9. Lock top to windshield header and check alignment of top cover. Adjust top cover as required.

10. Lower top and secure top cover to trimstick with staples or tacks spaced about two inches apart.
11. Cement, align and secure front roof rail rear weatherstrip outer ends (Fig. 3).
12. Seal, align and secure front roof rail front weatherstrip (Fig. 3).

FOLDING TOP SIDE QUARTER PAD ASSEMBLY

A right and a left side quarter (stay) pad assembly (Fig. 5) secures to the front roof rail and to the center bow assembly. The pad assemblies **do not secure to the front roof bow**. Pad assemblies consist of strong webbing material, a cloth cover, and soft foam padding approximately 1/4 inch thick. The left pad assembly is equipped with a plastic reinforcement at the inner rear corner as shown in Figure 5. Since extra retention is required to secure the reinforcement, four (4) 12 ounce tacks are used at this location. Other rear corners of pad assemblies are reinforced with two (2) 12 ounce tacks. Additionally, the rear of pad assemblies is secured with staples. Pad assemblies are secured at the front with attaching screws. Access for removal and installation of a side quarter pad assembly requires detaching the top cover across the front and at the front roof bow; and detaching the back curtain extension at the side affected.

Removal

1. Apply protective covers as required to interior trim, hood and rear deck of car.
2. With top lowered, detach following from front roof rail:
 - A. Front roof rail front weatherstrip (complete) (Fig. 3).
 - B. Front roof rail rear weatherstrip (at outer ends).
 - C. Top Cover.

NOTE: Before detaching top cover, reference mark complete front edge of front roof rail on top cover. Use care to avoid disturbing silencer attachment at front roof rail.

3. Raise top and lift several inches above windshield header. Detach hold-down cables at front (Fig. 4).
4. Turn front of top cover rearward and detach top cover front listing from front roof bow (Fig. 11).
5. Detach top cover where cemented to side quarter pad on left side between front and center roof bows (Item "6", Fig. 4).

6. Using scissors or equivalent tool, make lateral cut through side quarter (foam) pad in line with center bow. Foam pad is cut for access to back curtain extension attachment. Detach back curtain extension from center roof bow where extension overlaps side quarter pad assembly (Fig. 5).
7. Detach affected side of silencer assembly where cemented to side quarter pad assembly (Fig. 13).
8. Reference mark inner and outer edges of pad assembly on front roof rail and on center bow. Remove attaching screws securing pad assembly at front roof rail (Fig. 5).
9. Detach cemented cover of pad assembly (cemented at front, rear and outer edges) and carefully detach side quarter (foam) pad from webbing.
10. Detach side quarter pad assembly from center bow by removing staples and tacks, and remove pad assembly.

Installation

1. Install side quarter (stay) pad assembly as follows:
 - A. With top locked at windshield header, and top cover pulled away for access, position pad assembly at center bow reference marks as shown in Figure 5. With pad cover raised, secure webbing to center bow with nine (9) equally spaced staples. Align rear of pad flush with rear of center bow tacking strip.
 - B. If installing left side quarter pad assembly, position and install four (4) 12 ounce reinforcement tacks to secure rear of plastic reinforcement to center bow (Fig. 5).
 - C. Position and install two (2) 12 ounce reinforcement tacks to secure other rear corners of webbing at center bow (Fig. 5).
 - D. With aid of helper tighten the webbing by pulling forward, align webbing with reference marks at front roof rail and install inner four attaching screws (Fig. 5). Remove excess webbing at front roof rail trim line. Make opening in webbing for hold-down cable metal tab and for attaching screw.
2. Complete side quarter pad assembly build-up as follows:
 - A. With top several inches above windshield header, secure back curtain extension to center bow (Fig. 5). Space staples or tacks about two inches apart.
 - B. Lock top at front. Using trim cement sparingly, position and secure (foam) pad to side quarter webbing (Fig. 5). Make butt joint between foam pad on webbing and on back curtain extension. Secure butt joint with length of two (2) inch cloth-back body sealing tape.
 - C. Using trim cement sparingly around edges, position and secure cover of side quarter pad assembly.
3. Using trim cement sparingly, cement affected side of silencer assembly to side quarter pad assembly (Fig. 13).
4. Position and secure top cover front listing to front roof bow (Fig. 11). For further information see: "Top Cover Installation".
5. With top several inches above windshield header, position side quarter pad assembly at outer front corner and secure hold-down cable at front (Fig. 4).
6. Align and secure top cover to front roof rail (Fig. 3). See "Top Cover Installation".
7. Install front roof rail front and rear weatherstrips (Fig. 3).
8. If working on left side, lower top partially and apply trim cement, about three inches wide, between top cover and side quarter pad assembly as shown in Figure 4. Apply cement between front and center bows. Then raise and lock top. Align and slick down cemented surfaces, and allow cement to dry.
9. Remove protective covers and clean up as required.

FOLDING TOP GUTTER

The inward folding top rear gutter is constructed of convertible top trim material. The front of the gutter secures to the rear trimstick. The rear of the gutter secures to the body by means of a retaining rod and five (5) attaching clips (Fig. 14). The clips are spaced as follows: One clip on each side of each rear compartment lid hinge, and one clip at the rear center.

Removal and Installation

1. Detach back curtain assembly along bottom as described in "Back Curtain (Less Top Cover) Removal and Installation" (Fig. 5).
2. Remove original gutter by cutting along rear trimstick. Use care during original gutter removal not to cut folding top compartment bag (Fig. 14).

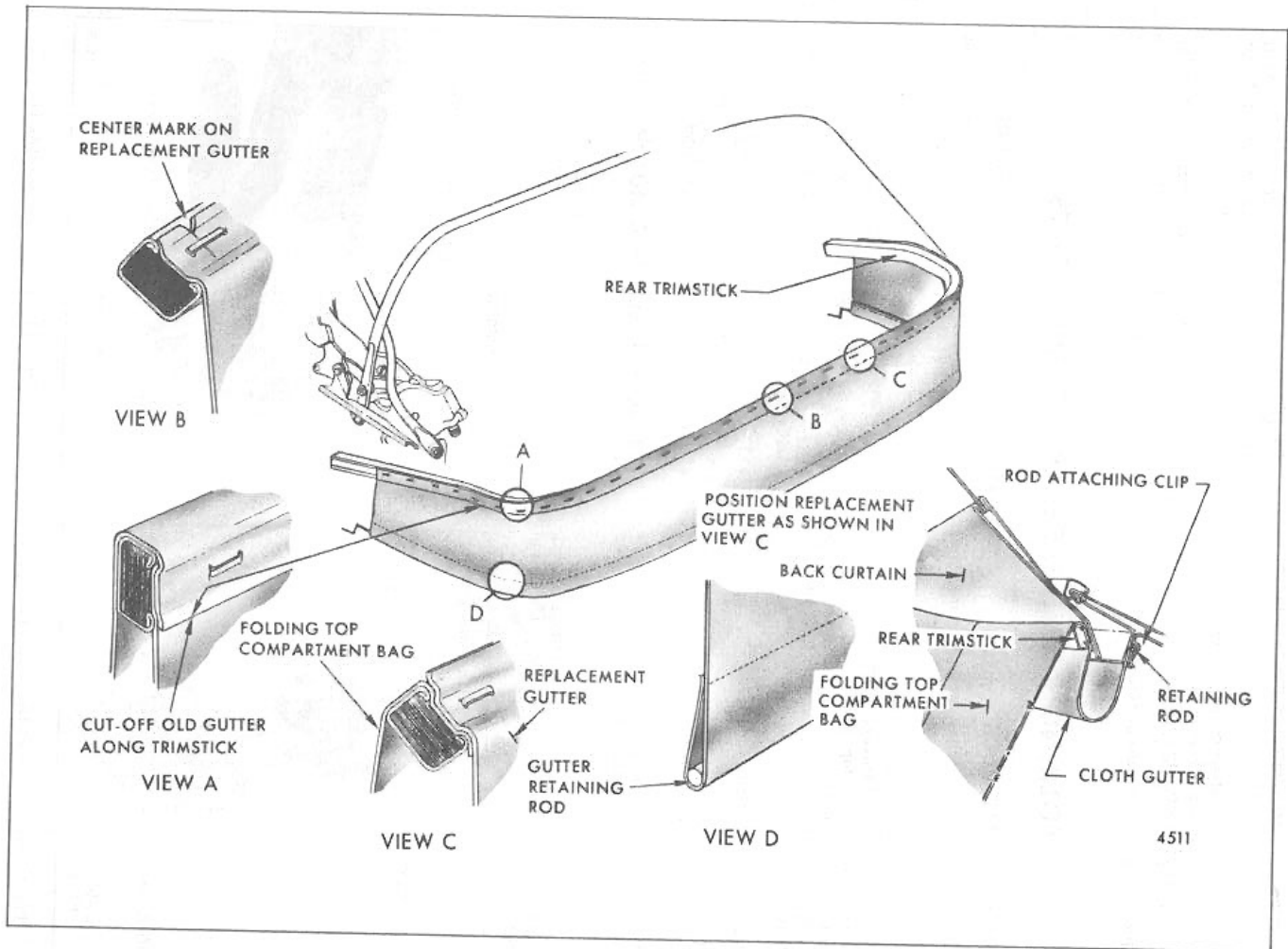

Fig. 14-Inward Folding Top Gutter Attachment

3. Determine and mark center on replacement gutter by folding gutter in half.
4. Transfer retaining rod from original to replacement gutter as shown in Figure 14. This operation can be done after securing gutter to trimstick.
5. Position center of replacement gutter over folding

top compartment bag on center of trimstick and staple or tack in place (View "C", Fig. 14). Start at center and work to each side. Space staples or tacks about four (4) inches apart.

6. Install back curtain and top cover assemblies as described in "Back Curtain (Less Top Cover) Removal and Installation".

FOLDING TOP HARDWARE COMPONENTS

FRONT ROOF RAIL LOCK

IMPORTANT: A safeguard has been built into the front roof rail lock to prevent moving the lock handle to the closed position when the top is unlocked. Lowering a top with the lock handle in the closed or locked position causes breakage of the handle. The safeguard consists of a stop to prevent rotating the handle from the open to the closed position unless the lock hook is engaged. Do not attempt to force the lock handle past the stop.

Removal and Installation

1. Manually, unlock and support front roof rail several inches above windshield header.
2. With lock handle in open position as shown in Figure 15, detach spring, remove lock attaching screws and remove lock.
3. To install, reverse removal operations. Check operation of locks. Always lock left side of top before locking right side.

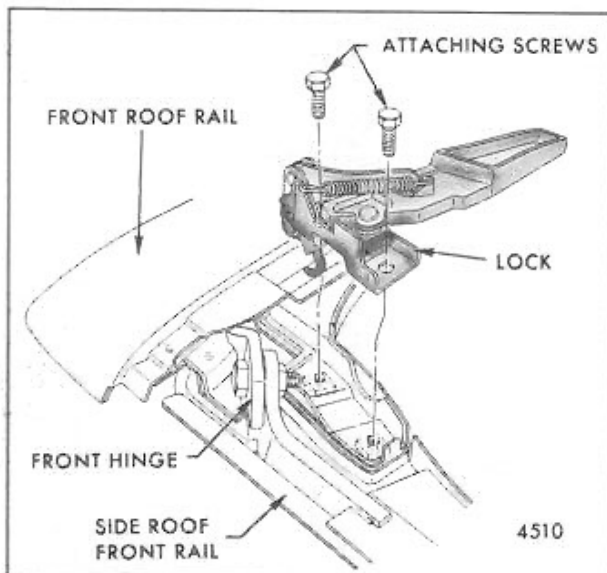

Fig. 15-Front Roof Rail Lock Attachment

FRONT ROOF RAIL LOCATING PIN

A locating pin, of plastic construction, secures to the front of each side roof front rail by an attaching screw (Fig. 16).

Removal and Installation

1. Lower top part-way, or completely.
2. Remove attaching screw and remove locating pin (Fig. 16).
3. To install, position locating pin on side roof front rail and install attaching screw.
4. Raise and lock top at windshield header.

FOLDING TOP ELECTRIC MOTOR AND/OR RELAY

The folding top electric motor and relay are secured to the rear seat back panel and are accessible in the rear seat area (Fig. 17).

Removal and Installation

1. Remove rear seat cushion and rear seat back.

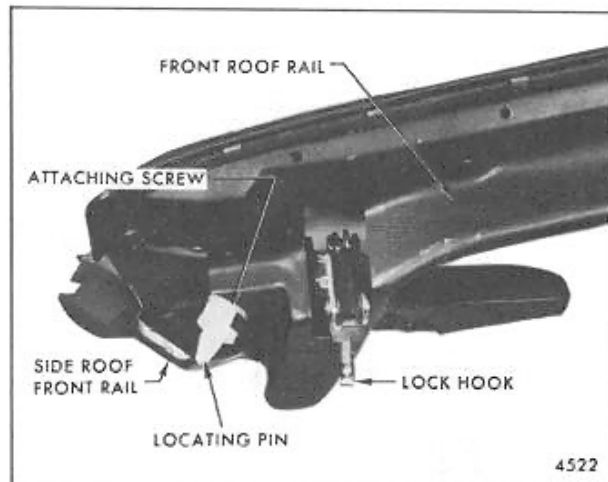

Fig. 16-Front Roof Rail Locating Pin

2. Detach drive cables at each top actuator.
3. Detach electric motor connectors from relay (Fig. 17).
4. Detach relay attaching screw and remove relay.
5. Remove screw securing motor ground to rear seat back panel.
6. Detach rubber grommets securing motor support to rear seat back panel (Fig. 17).
7. Detach right and left drive cables from electric motor reduction unit (Fig. 17).
8. Remove two attaching screws securing motor support to motor and remove motor.

9. To install, reverse the removal operations. To ease installation of motor and attaching bracket, apply solvent (mineral spirits or equivalent) to grommets on motor bracket. Check operation of motor for proper ground before installing trim.

FOLDING TOP ACTUATOR DRIVE CABLE - Right and/or Left

Removal and Installation

1. Remove rear seat cushion and rear seat back.
2. Detach drive cable at top actuator assembly.
3. Detach right and/or left drive cable at electric motor reduction unit (Fig. 17). For removal of left drive cable, first detach motor.

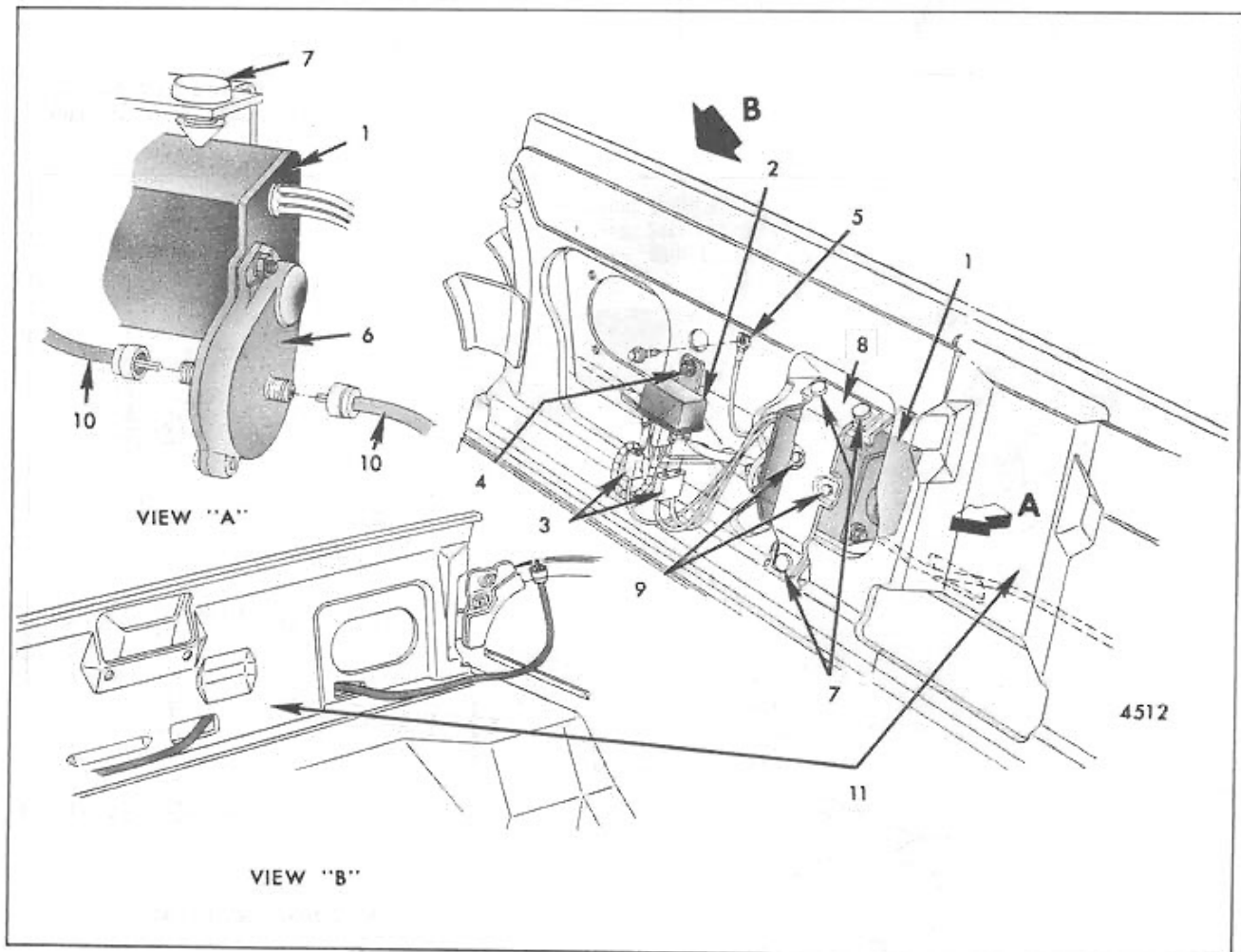

Fig. 17-Folding Top Electric Motor and Relay

- | | | | |
|------------------------------|------------------------------------|----------------------------------|--------------------------|
| 1. Electric Motor | 4. Relay Attaching Screw | 6. Electric Motor Reduction Unit | 9. Motor Attaching Screw |
| 2. Relay | 5. Motor Ground to Seat Back Panel | 7. Rubber Grommet(s) | 10. Drive Cable |
| 3. Electric Motor Connectors | | 8. Motor Support | 11. Seat Back Panel |

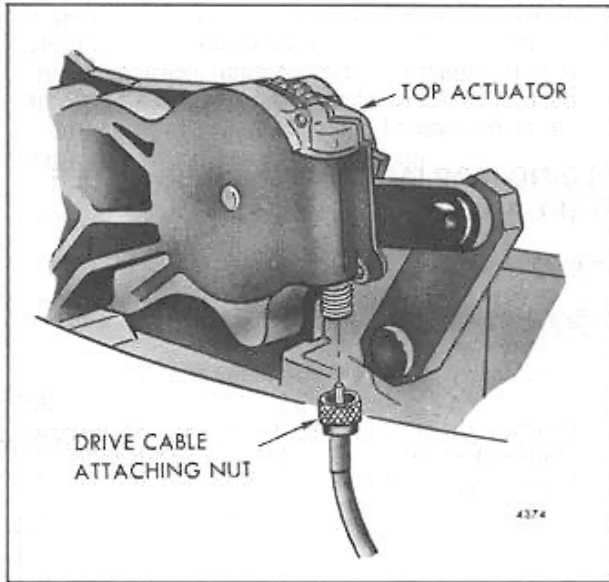

Fig. 18-Drive Cable To Top Actuator Attachment

4. To install, reverse removal operations. To facilitate engagement of drive cable, push and rotate cable opening on actuator by finger or with suitable tool.

BACK WINDOW GUIDE CONTROL LINK AND SPRING

The purpose of guide control links and springs at the back window is to guide the back window downward beyond the rear trimstick when lowering the inward folding top. As shown in Figure 19, the links and springs secure to attaching brackets at the back window and at the folding top compartment floor. The actuator springs are located under the folding top compartment bag. Inward folding tops must not be lowered if control links and/or actuator springs are disconnected for any reason.

Removal and Installation

1. With top in raised position, remove hair pin clip and washer from link attaching stud at back window.

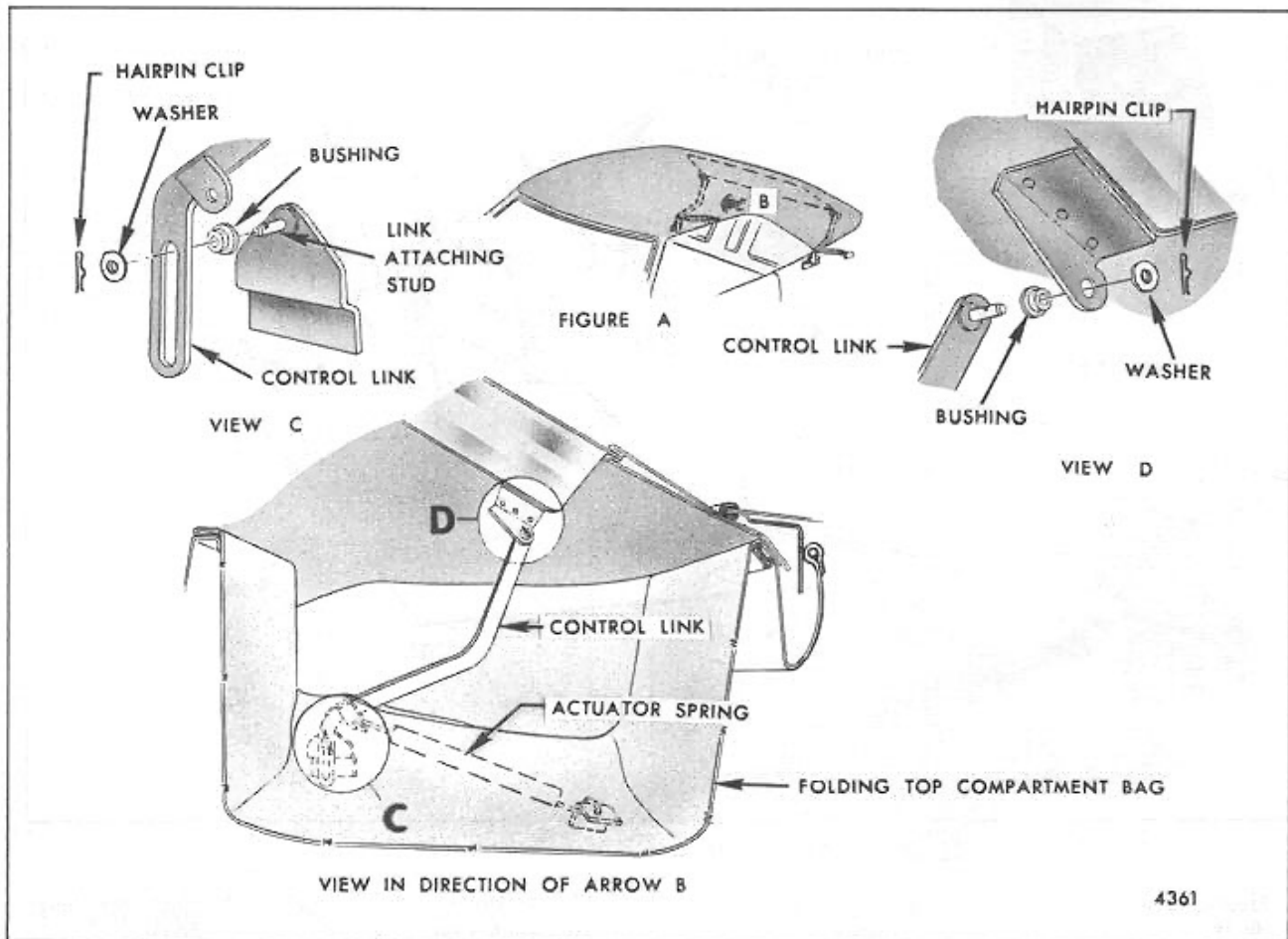

Fig. 19-Back Window Guide Control Link Attachment

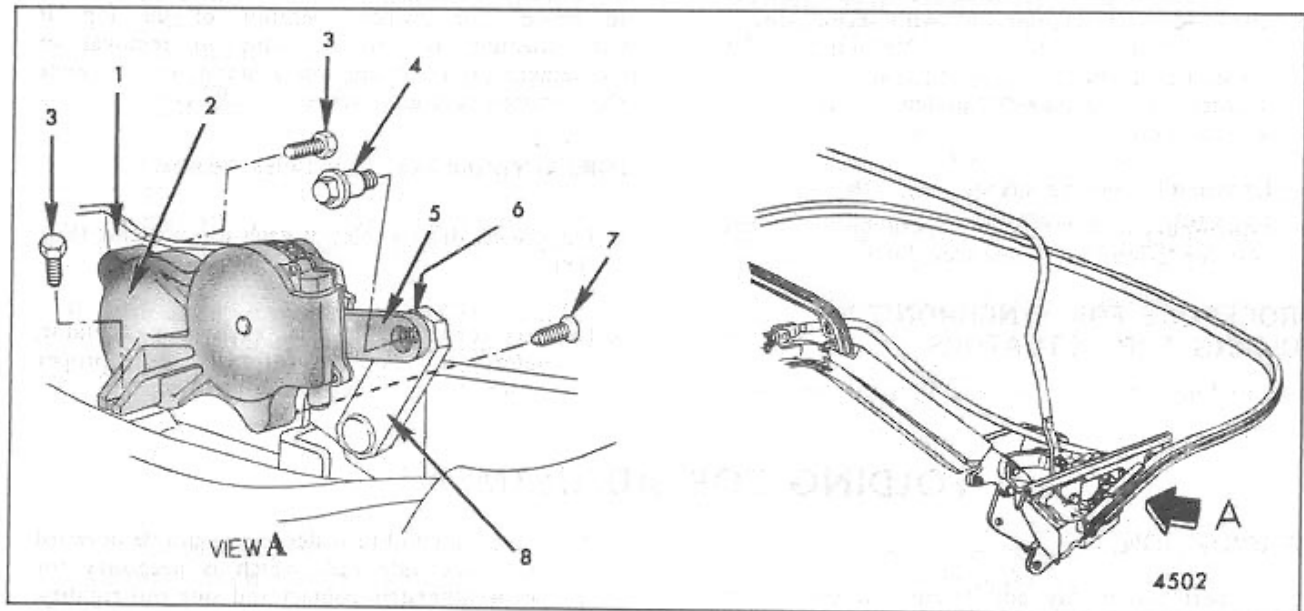

Fig. 20-Folding Top Actuator Attachment (View in Direction of Arrow "A")

- | | | |
|--------------------------|------------------------------------|--|
| 1. Main Hinge | 4. Shoulder Bolt | 7. Flat-head, Cross-recessed Attaching Screw |
| 2. Top Actuator Assembly | 5. Actuator Sector Arm | 8. Side Rail Actuator Link |
| 3. Attaching Screws | 6. Shoulder Bolt Locking Set Screw | |

- Carefully lift control link, which is under spring tension, from attaching bracket. While carefully lowering control link, lift compartment bag over control link and lay control link on floor. Bushing need not be removed from stud unless necessary.
- Through opening in compartment bag, detach and remove actuator spring, first from link, then from floor bracket.
- Working through opening in compartment bag or through rear compartment, remove hair pin clip and washer from control link front attaching stud and remove control link.
- To install, reverse removal operations.

FOLDING TOP ACTUATOR ASSEMBLY

A folding top actuator assembly is secured to each main hinge by attaching screws (Fig. 20) and to the side rail system by a shoulder bolt. The shoulder bolt threads into the actuator link and is locked in place with a set screw. Actuator assemblies are operated by electrically powered drive cables.

Removal

Removal and installation of top actuators is easier with the top lowered. However, actuators can be

replaced with the top raised.

- Remove rear seat cushion and rear seat back.
- Reposition bottom of main hinge cover panel on side affected for access to flat-head attaching screw.
- Disconnect drive cable from actuator assembly (Fig. 18).
- Remove actuator attaching screws (Fig. 20). If top is lowered, side rails require slight raising manually, plus required support, for access to rear flat-head attaching screw.
- Loosen set screw in side rail actuator link and remove shoulder bolt securing sector arm to actuator link.

Installation

- Position top actuator assembly to main hinge and install in reverse order of removal. Finger start two attaching screws on inner face of main hinge.
- Align outer leg of actuator with main hinge attaching hole, vertically position outer attaching screw (Fig. 20) and finger start screw.

3. Align side rail actuator link with sector arm of actuator. Lubricate shoulder of attaching bolt with grease (Lubriplate or equivalent), and install bolt. Tighten set screw on side rail actuator link to lock attaching bolt.
4. Tighten all attaching screws.
5. Synchronize actuators, check operation of top and install previously removed trim parts.

PROCEDURE FOR SYNCHRONIZING FOLDING TOP ACTUATORS

Both folding top actuators must be synchronized or

"in phase" for proper operation of the top. If synchronization is necessary due to removal or replacement of a folding top actuator, or for some other service operation, proceed as follows:

1. Raise top and lock at windshield header.
2. Disconnect drive cables at each top actuator (Fig. 18).
3. Connect drive cables to each top actuator. Actuators are now synchronized for proper operation of top. Check operation of top.

FOLDING TOP ADJUSTMENT

DESCRIPTION

Before performing any adjustments on the inward folding top, the mechanic should read and understand the complete adjustment section as covered in this manual. Knowledge of the design, operation, attachment and adjustment sequence of component units is essential to the mechanic performing top alignment operations. Side roof rail assemblies are designed to provide three basic functions for the proper operation of the inward folding top.

1. The first function provides a lifting tension in the side rail system when the top is down or stacked. This tension is required to assist and coordinate the proper unfolding of the side roof rails when raising the top. The tension is achieved by an outward pull of the rear control link at the mounting plate.

The adjustment is controlled by the serrated bushing of the control link.

Improperly tensioned rear control links can cause binding and/or damage conditions to the rail system when raising the top.

2. The second function provides proper height and length to the side roof rails. Height of the side rails is important to side glass alignment. Length of the side rails positions the front roof rail locating pin with the striker in the windshield header.

The height and length adjustments are controlled simultaneously by the setting of the side roof rail set screw.

When side rails have mispositioned set screws, the windows cannot be aligned properly and locating pins cannot be aligned with the windshield header.

3. The third function provides a measurable outward force by the side rails which is necessary for proper weatherstrip contact and side rail rigidity. The outward force of each side rail is adjustable and rests against the center bow stop on each side. The center bow assembly, consisting of the center bow and side roof outer rear rails, straddles the inward folding side roof rails.

Adjustment of the outward force is controlled by the fore-aft setting of the rear control link mounting plate.

Improper positioning of the rear control link mounting plate can cause corresponding folding top misalignment problems and/or, if over-adjusted, damage to folding top components.

CHECKING TENSION ON STACKED FOLDING TOP

The inward folding top, when down or stacked, must possess a degree of tension in the side rail system to assist and coordinate the proper unfolding of the right and left side rails when the top is raised. In event an inward folding top shows signs of difficulty upon stacking or unfolding, stop operation of top immediately. Check tension adjustment on folded top as follows:

1. Lower top into folding top compartment.
2. Disconnect both drive cables from top actuator units (Fig. 18).
3. Check for tension on stacked top as follows:
 - A. Push down on one end of front roof rail and suddenly release pushing force:
 1. Proper tension is noted when front roof rail springs up noticeably and significantly, but not too far.

2. Lack of tension is noted when front roof rail does not spring up noticeably and significantly. Lack of tension in rails indicates top control link requires adjustment.
 3. Excessive tension in rails is noted when front roof rail springs up too far or excessively. Excessive tension indicates top control link requires a reduction of tension.
- B. Push down on opposite end of front roof rail and check for presence of tension as in "A" above.
1. Tension must be proper and approximately equal on both sides.
- C. If tension is lacking, discrepant or unequal on both sides, proceed with "Folding Top Stacked Position Tension Adjustment".

FOLDING TOP STACKED POSITION TENSION ADJUSTMENT

Stacked or down position tension adjustment must be completed before side roof rail (up position) tension adjustment is attempted. Stack tension adjustment is not affected by side roof rail (up position) tension adjustment. However, side roof rail (up position) tension adjustment is affected by stack (or down position) adjustment.

To obtain proper folding top stack tension adjustment, proceed as follows:

1. Lower top into folding top compartment.
2. Disconnect drive cables from both top actuator units (Fig. 18).
3. Loosen top control link attaching nut (View "A", Fig. 21) on each side. Allow front and side roof rails to lay normally in folding top compartment.

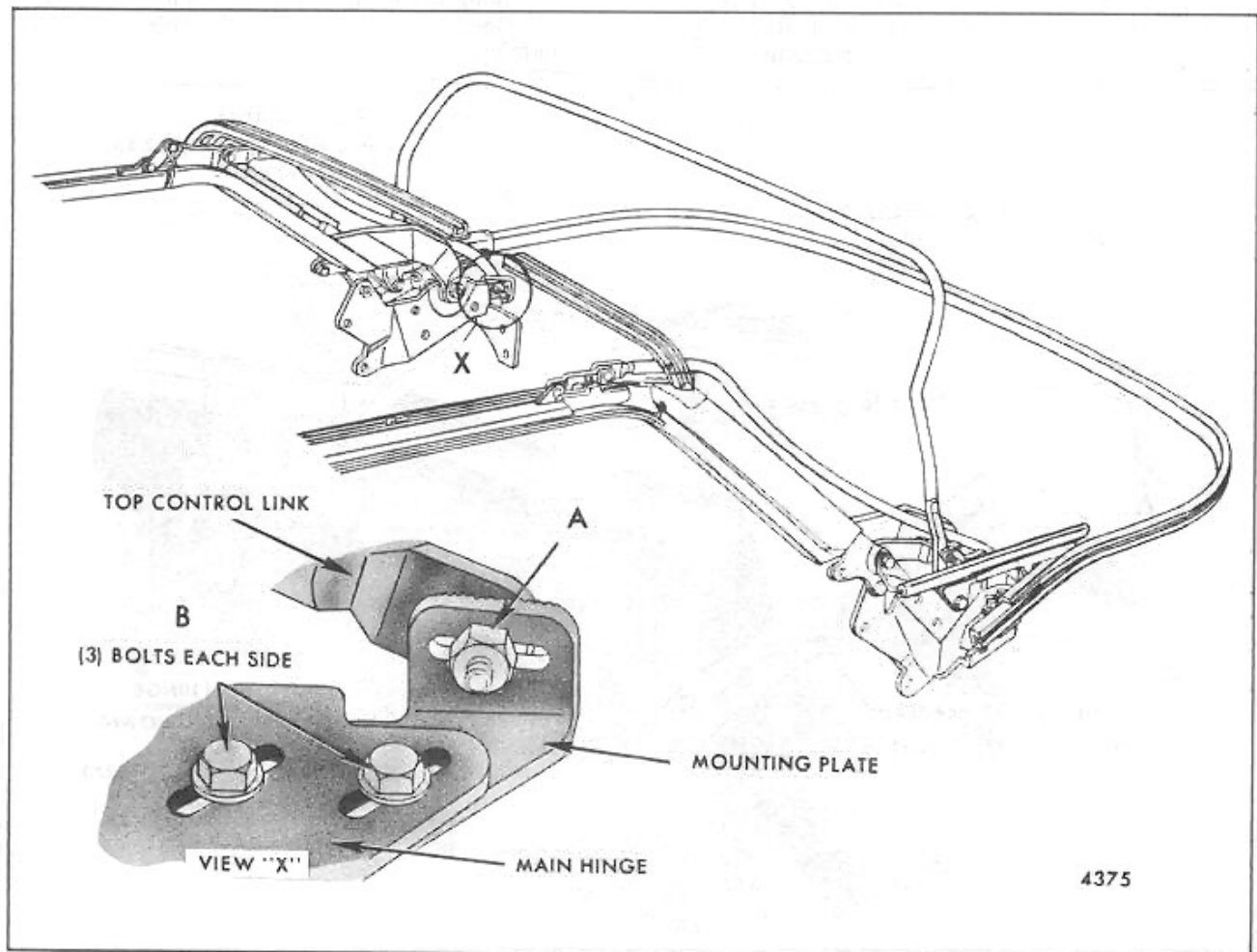

Fig. 21-Top Control Link and Mounting Plate Attachment

4. Position top control link serrated bushing outward one notch at a time on each side by raising folded side rail and tighten attaching nut.
5. Check for tension on stacked folding top.
6. Repeat step 4 as necessary until proper and equal tension is obtained on each side. Tighten attaching nuts to proper torque. On a properly stacked top the front roof rail is parallel to the belt line of the car, and allows for normal top boot installation.
7. Before raising top, scribe and then loosen three control link mounting plate attaching bolts (View "B", Fig. 21) on affected sides. Bolts are accessible on right side. Access to "left" mounting plate attaching bolts requires removal of left top actuator unit (See: "Folding Top Actuator Assembly Removal and Installation").

IMPORTANT: The required loosening of mounting plate attaching bolts in step 7 above, affects side roof rail (up position) tension adjustment. Therefore, proceed with "Side Roof Rail (Up Position) Tension Adjustment" in this section.

LOCATING PIN AND SIDE ROOF RAIL HEIGHT ADJUSTMENT

Description

When raising a top, always lock the left lock handle first. The left striker guide hole is round and the right striker guide hole is slotted laterally. To lock the left side of the top, pull down on the front roof rail with one hand to position the left locating pin in the striker hole. Then rotate the lock handle to the locked position. Repeat the operation on the opposite side. Manual assistance (up to 30 pounds) may be required to position locating pins in the windshield header. This is a normal condition.

Figure 22 illustrates a body dimensional specification from a bolt on the main hinge to the striker on the windshield header. The distance from the center of the striker guide hole, "A", to the center of the main hinge bolt, "B" as shown, is $56\frac{7}{32}$ " plus or minus $\frac{3}{16}$ ". Adding the tolerance, the maximum measurement is $56\frac{13}{32}$ ". Subtracting the tolerance, the minimum measurement is $56\frac{1}{32}$ ".

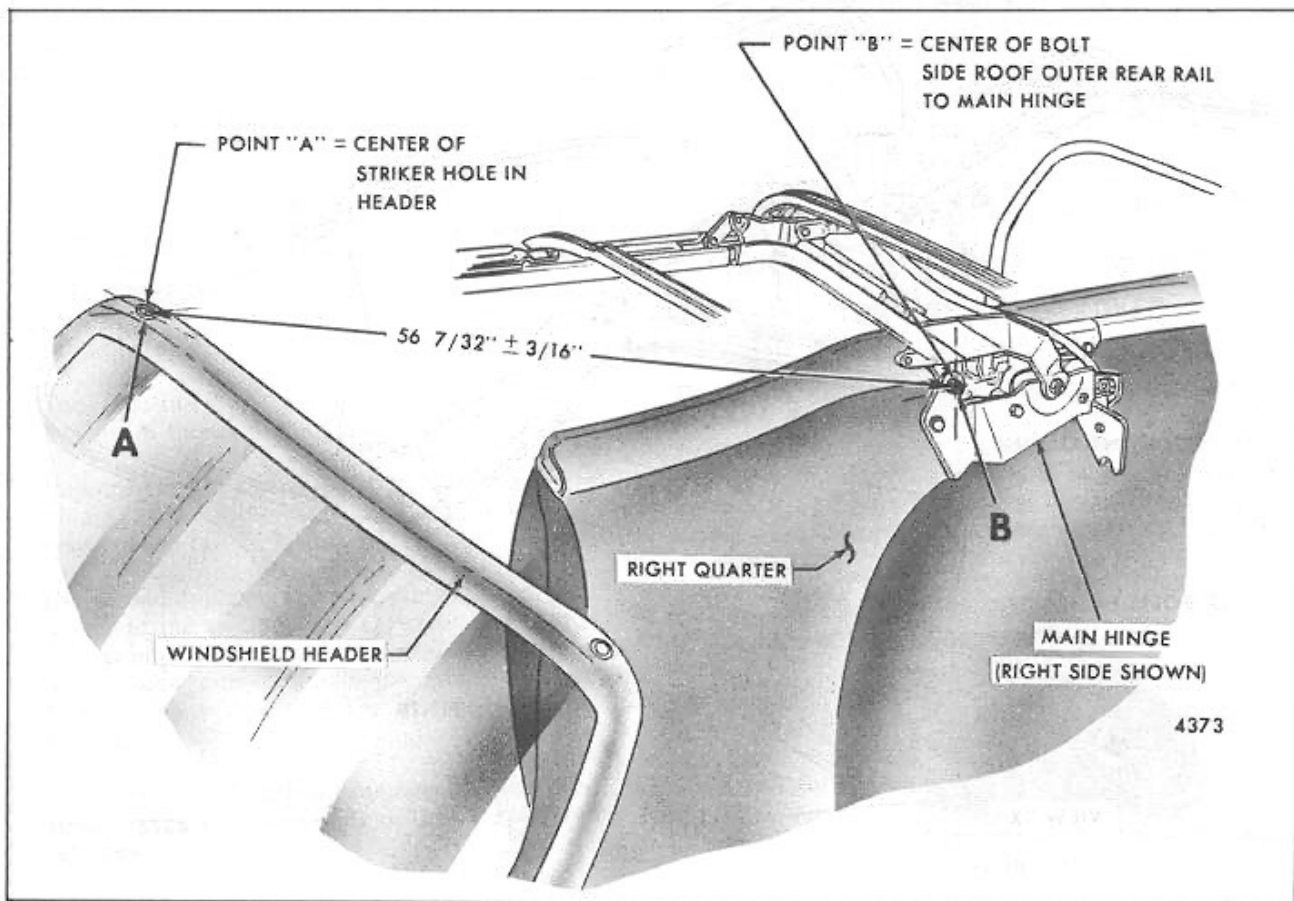

Fig. 22-Body Dimensional Specification

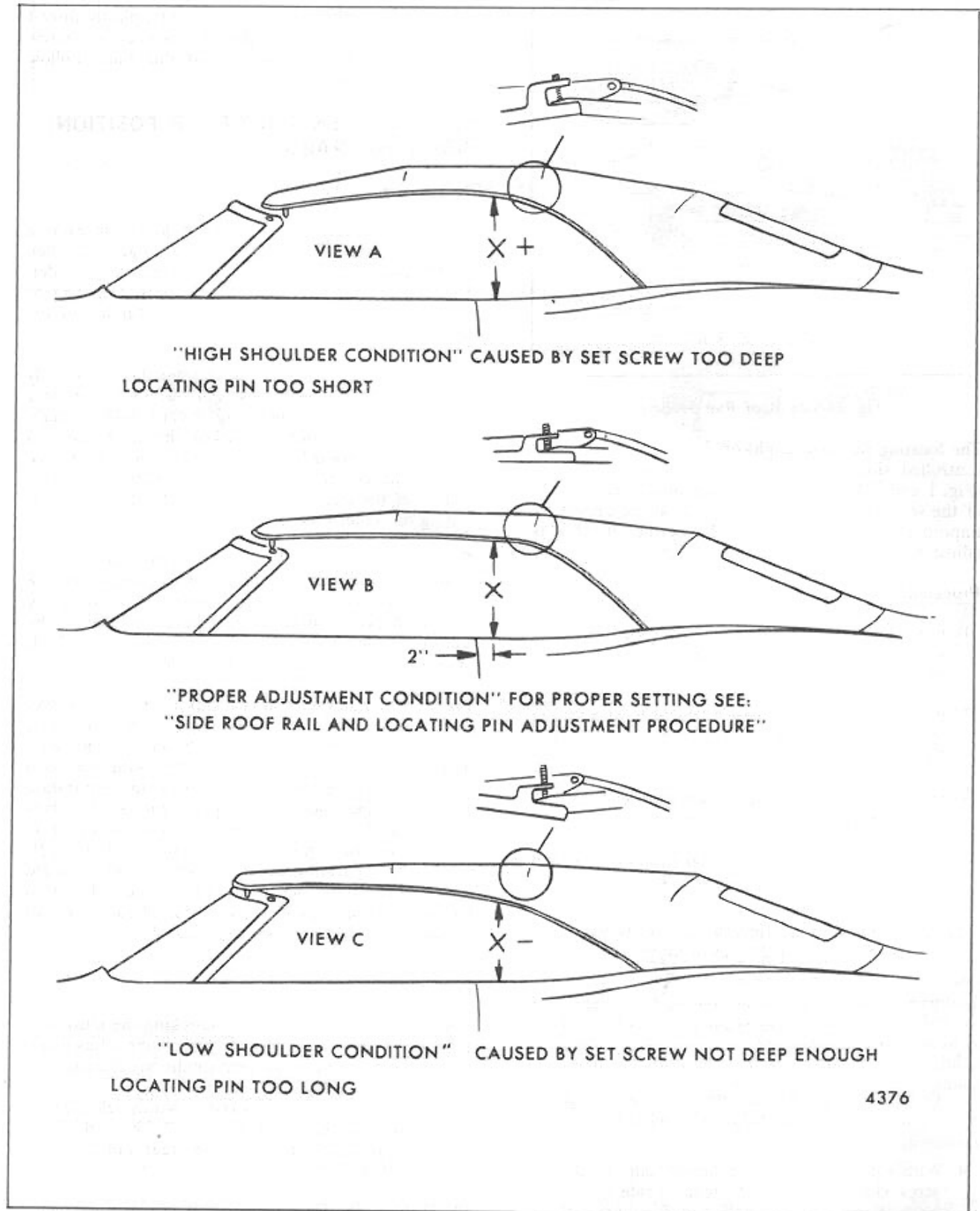

Fig. 23-Side Roof Rail and Set-Screw Adjustment

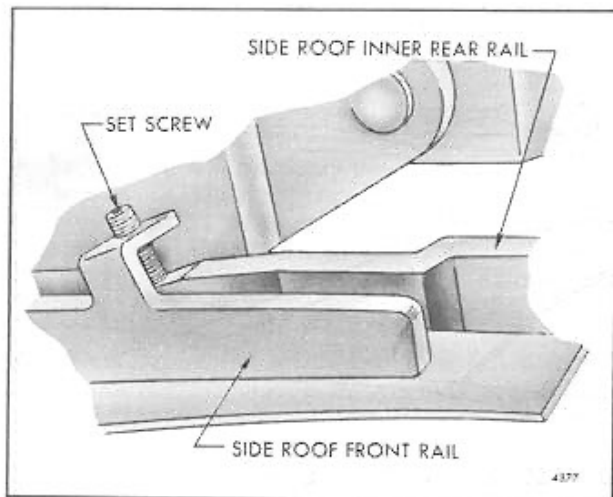

Fig. 24-Side Roof Rail Set-Screw

The locating pin and height of the side roof rails are controlled simultaneously by the side rail set screw (Fig. 1 and 24). Figure 23 portrays proper adjustment of the set screw and conditions that can be caused by improperly adjusted set screws. While the set screw is adjustable, it has only one proper setting.

Procedure

1. Raise top and back off set screw located at center of each side rail (Fig. 24). Set screw is 1/8 inch hex head.
2. Position locating pins in windshield header striker guides and lock top to header. Position left pin first.
3. Manually position and then support each side roof rail at proper height over side windows.

Specified dimension from outer corner of side rail to quarter panel (Fig. 25) is as follows:

- A. Dimension "A" (measured directly with tape measure) is 16-1/2" plus or minus 1/8".
 - B. Dimension "B" (determined with straight edge and vertical measurement as shown) is 13-1/8" plus or minus 1/8".
 - C. Both dimensions are determined at a point two inches rearward of the body lock pillar.
4. With side rails at proper height, adjust each set screw clockwise until it bottoms at side rail. Then, back off set screw one-half turn. Readjust each set screw, if necessary to correct side rail height, after all other tensioning adjustments are completed.

NOTE: Application of high quality, plastic thread adhesive to exposed threads on each set screw (Fig. 24) is recommended at this time. Follow label directions.

CHECKING TENSION OF (UP POSITION) SIDE ROOF RAILS

Description

The side roof rails of an inward folding top exert a specified outward force at the center hinge area when the top is raised and locked at the windshield header. The outward force is required for proper contact of weatherstrips to side windows and for stability of the side roof rails.

Figure 2 illustrates how the center bow assembly (consisting of the center bow and side roof outer rear rails) straddles the side roof inward folding rails. When the top is raised and locked, the inner side rails rest with an outward pushing force on a stop at each end of the center bow. Figure 26 portrays a cross-section of the left and right side roof inner rear rails resting on center bow stops.

The outward force exerted by each side rail is adjustable and can be measured accurately at the center bow area in the car. Figure 27 illustrates a tension checking tool which is required to measure the tension of side roof rails. Tool J-23790 or BT-7111, (which is shown) or equivalent may be used.

The side roof rail tension checking procedure involves separating one side roof rail inwardly from the center bow stop by pulling simultaneously on both side roof inner rear rails. The side roof rail with the least tension always separates first. Check the separation with due care and with proper lighting. The best location to check the separation is inside the car from the rear of the center bow as shown in Figure 28. Check the separation accurately on the side affected with a 1/16" shim. Before tensioning side rails with a tensioning tool, study the relationship of each side rail to center bow stop as shown in Figure 26.

Procedure

Following is the procedure for checking the tension of inward folding side roof rails. Corrective adjustments are indicated by the alignment conditions present.

1. With top raised and locked at windshield header, mount tension checking tool (J-23790 or BT-7111, or equivalent) on each inner rear rail at center bow (Fig. 27).
2. Tighten tensioning device in small increments while observing ends of center bow for separation at affected side rail. Tighten tensioning device

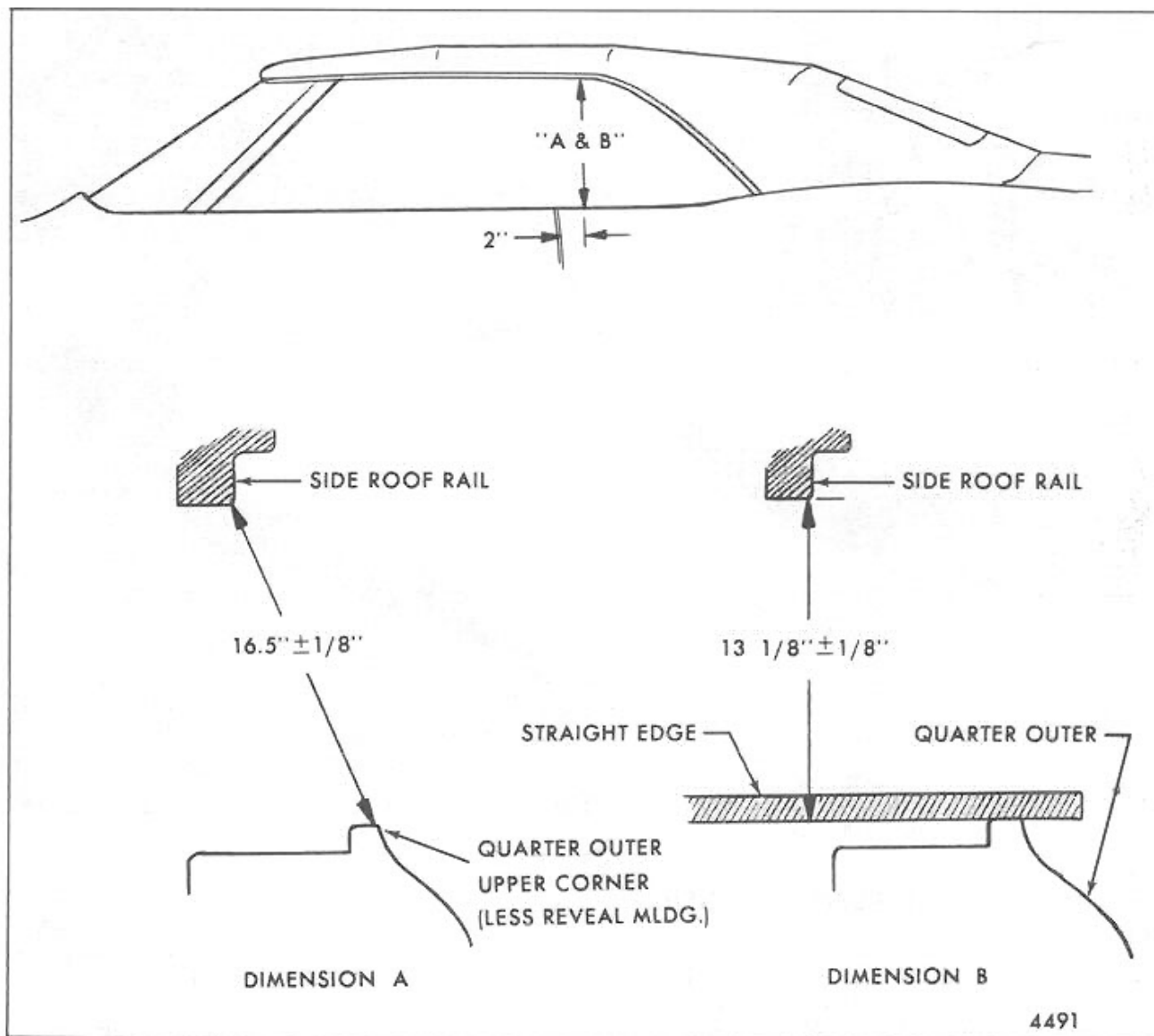

Fig. 25-Height of Side Roof Rails

- until a $1/16''$ separation occurs. Use flashlight and $1/16''$ shim. The separation **should not exceed** $1/16''$.
- When ($1/16''$) separation occurs at one side rail at a scale reading below 50 pounds, **same side rail** is insufficiently tensioned and requires adjustment. Adjust affected control link mounting plate rearward to increase tension.
 - When ($1/16''$) separation occurs at one side rail at a scale reading in excess of 70 pounds, **opposite side rail** is overtensioned and requires adjustment. Adjust affected control link mounting plate forward to decrease tension.
 - Cross-check body with tram gauge or tape measure as described in Figure 29. Side rails are in good alignment when both diagonal measurements are within $3/8$ of an inch. Re-check measurements to assure accuracy. If difference between measurements exceeds $3/8$ of an inch, **side rail of longer measurement** requires adjustment to decrease tension. In this event, adjust affected control link mounting plate forward.
 - An inward folding top is in proper alignment when following two conditions are present:
 - When tension checking tool indicates **50 to 70** pounds of force to separate side rail $1/16$ of an inch from center bow stop.

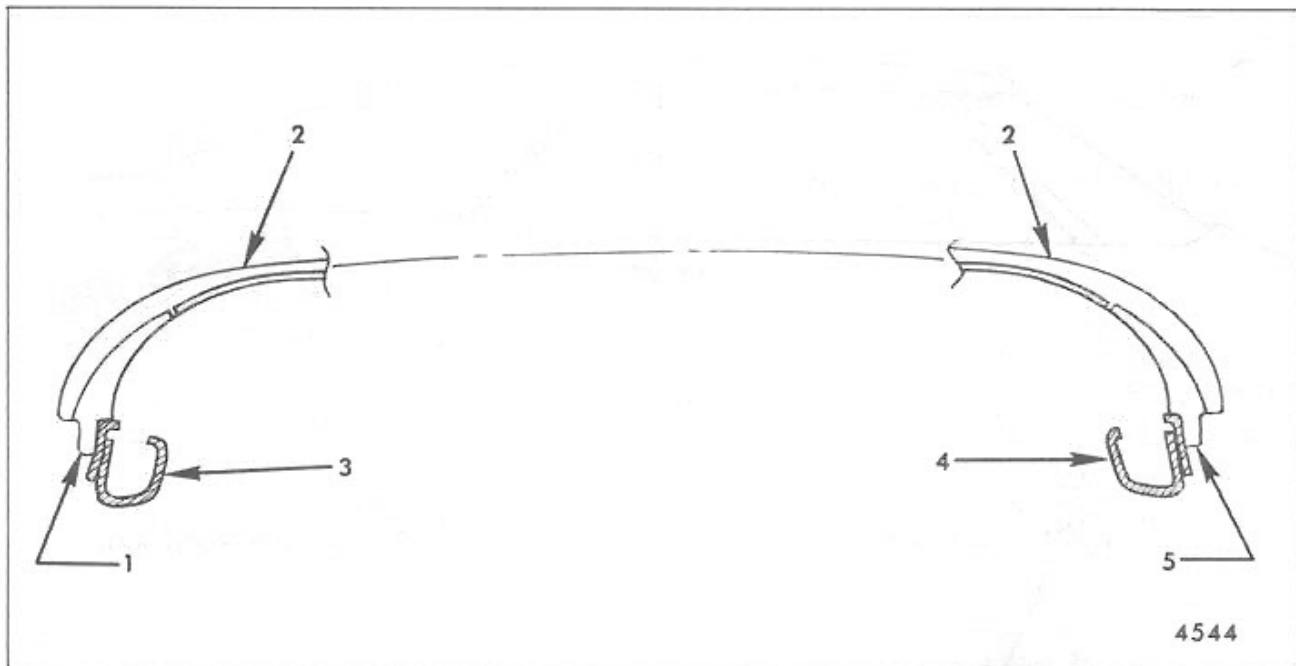

Fig. 26-Cross Section of Side Rail to Center Bow Stop Alignment

- | | | |
|---------------------------|--------------------------------------|----------------------------|
| 1. Center Bow Stop (Left) | 3. Side Roof Inner Rear Rail (Left) | 5. Center Bow Stop (Right) |
| 2. Center Bow Assembly | 4. Side Roof Inner Rear Rail (Right) | |

B. When diagonal measurements illustrated in Figure 29 are **within 3/8 of an inch**.

SIDE ROOF RAIL UP POSITION TENSION ADJUSTMENT

In event one or both side roof rails require tension adjustment, it is first necessary to check and, if necessary, to complete the "Folding Top Stacked Position Adjustment".

In event the tension checking procedure reveals that only the **right side rail** requires adjustment, proceed as follows:

1. Raise top two to three feet above windshield header.
2. Scribe fore-aft location of mounting plate at main hinge for accuracy of controlling adjustment.
3. Loosen three mounting plate attaching bolts (Fig. 21).
4. Using pry-bar or suitable tool, slide mounting plate in small increments (1/16 to 1/8 of an inch) "forward" (to decrease tension), or "rearward" (to increase tension).

5. Tighten only two mounting plate bolts for checking purposes.

6. Raise and lock top at windshield header.

7. Check tension of side roof rails with tension checking tool. (See: "Procedure For Checking (Up Position) Side Roof Rail Tension").

8. Repeat adjustment of mounting plate (Steps 3,4,5,6 and 7) until tension checking tool indicates 50 to 70 pounds of force to separate side rail from center bow stop; and diagonal measurements illustrated in Figure 29 are within 3/8 of an inch.

9. Tighten all three mounting plate attaching bolts.

10. Check operation of top.

In event the checking procedure reveals that the **left side rail** requires tension adjustment, proceed as follows:

1. Lower top.
2. Remove left top actuator assembly (See: "Folding Top Actuator Removal and Installation").

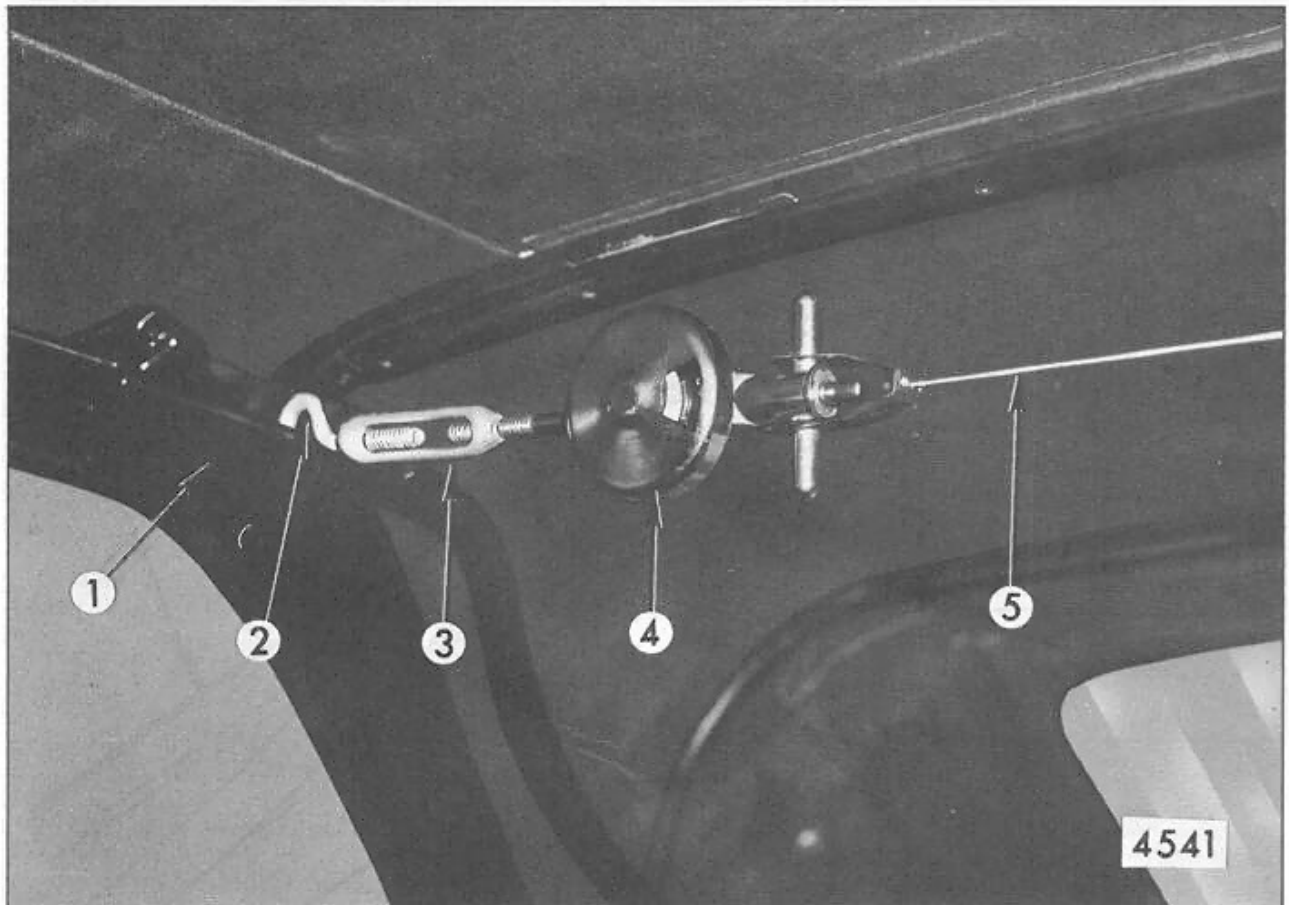

Fig. 27-Inward Folding Top Tension Checking Tool

- | | | | |
|------------------------------|-------------------|----------------|------------------|
| 1. Side Roof Inner Rear Rail | 2. Attaching Hook | 3. Turn-Buckle | 4. Tension Scale |
| | | | 5. Cable |
3. Detach drive cable from right top actuator assembly.
 4. Scribe fore-aft location of mounting plate at left main hinge for accuracy of controlling adjustment.
 5. Loosen three mounting plate attaching bolts (Fig. 21).
 6. With aid of helper, raise and position top about two feet above windshield header.
 7. Using pry-bar or suitable tool, slide mounting plate in small increments (1/16 to 1/8 of an inch) "forward" (to decrease tension), or "rearward" (to increase tension).
 8. Tighten only two mounting plate bolts for checking purposes.
 9. Manually, raise and lock top at windshield header.
 10. Check tension of side roof rails with tension checking tool. (See: "Procedure For Checking (Up Position) Side Roof Rail Tension").
 11. Repeat adjustment of mounting plate (Steps 5,6,7,8,9 and 10) until tension checking tool indicates 50 to 70 pounds of force to separate side rail from center bow stop; and diagonal measurements illustrated in Figure 29 are within 3/8 of an inch.
 12. Tighten all three mounting plate attaching bolts, install previously removed parts, and check operation of top.

FRONT ROOF RAIL LOCK HOOK ADJUSTMENT

Conditions of unsatisfactory lock operation caused by the lock hook can be corrected as follows:

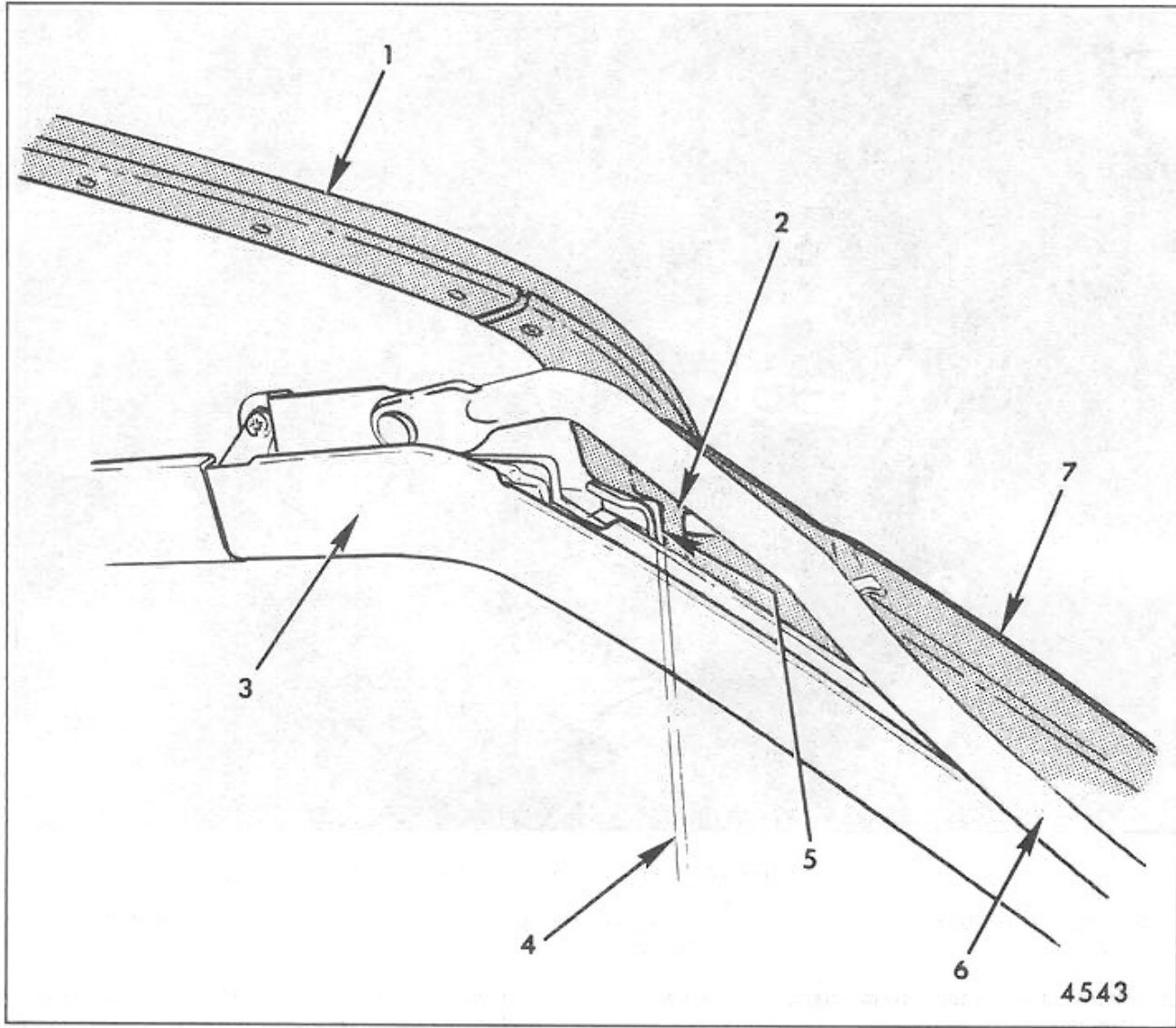

Fig. 28-Checking Separation of Side Rail from Center Bow Stop (Inside Car)

- | | | |
|------------------------------|--|--|
| 1. Center Bow | 4. 1/16" Separation Occurs Here | 6. Rear Control Link |
| 2. Center Bow Stop | 5. Check With Shim in Direction of Arrow | 7. Side Roof Outer Rear Rail (Part of Center Bow Assembly) |
| 3. Side Roof Inner Rear Rail | | |

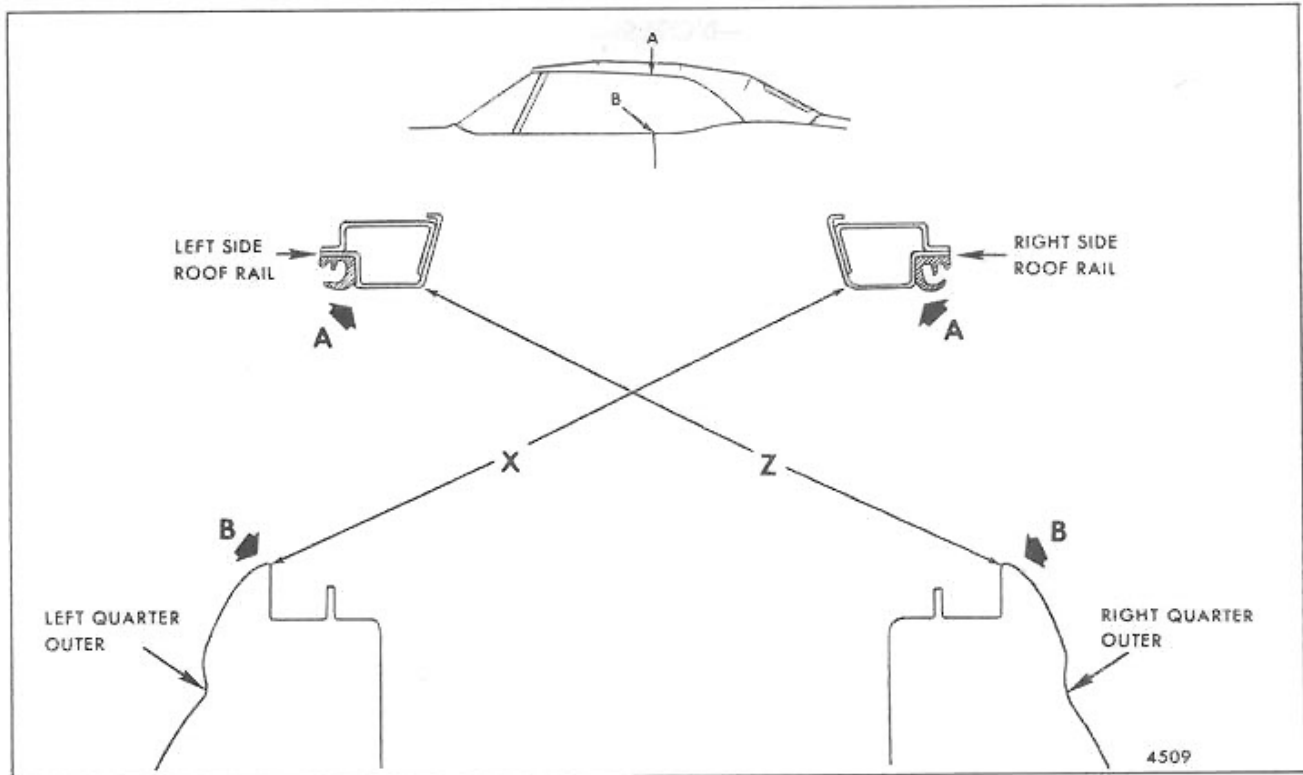

Fig. 29-Diagonal Check of Side Roof Rails

1. To tighten or increase locking action, turn lock hook clockwise.
2. To reduce or decrease locking action, turn lock hook counter-clockwise (Fig. 15).

IMPORTANT: Always lock left side of top before locking right side.

FOLDING TOP MAIN HINGE "INWARD" ADJUSTMENT

In event it is necessary to shim the main hinge inboard at the side quarter to improve appearance or operation of the top, the operation can be done as follows:

1. Remove rear seat cushion and rear seat back.
2. Remove rear quarter trim assembly, quarter filler panel and main hinge cover panel on side affected.
3. Remove main hinge upper front attaching bolt (Fig. 30).
4. Loosen main hinge rear two attaching bolts, and loosen lower front attaching nut.
5. Install shim stock of suitable thickness made up of a combination of steel washers, 1/16" and 1/8"

thick, at upper front attaching bolt location. Position upper front bolt to retain washer shims but do not tighten bolt at this time.

6. Tighten main hinge attaching bolts in following sequence: (Fig. 30)
 - A. Rear two attaching bolts
 - B. Lower attaching nut
 - C. Upper front attaching bolt
7. Check operation and alignment of top.
8. Install previously removed parts.

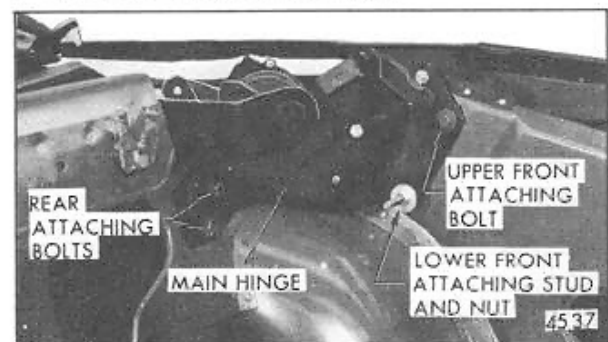

Fig. 30-Inward Folding Top Main Hinge Attachment

